

# LIBE

vitrina 78x115  
vitrine 78x115  
vitrina 78x115  
vetrina 78x115

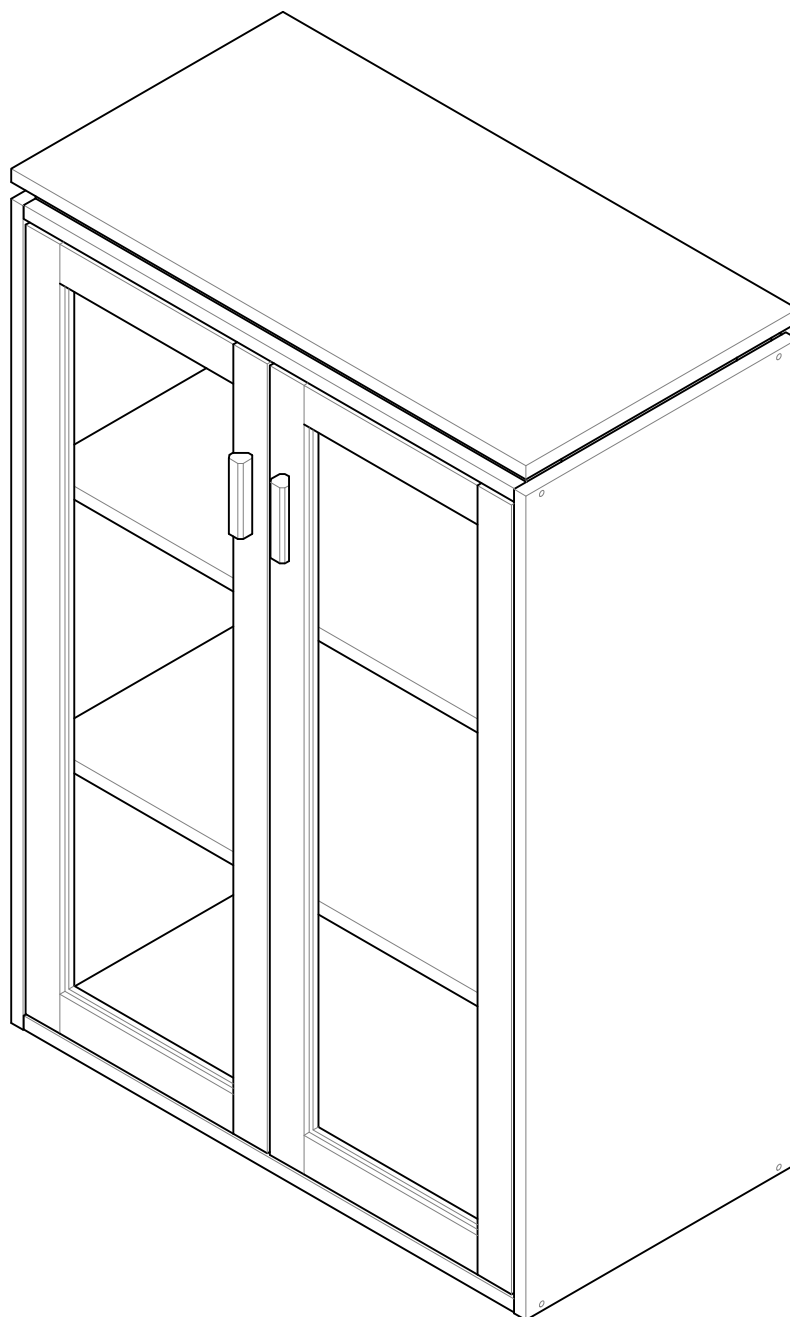

---

L U F E



Libe 2 vitrina 1/2 (x1)

---

Libe 2 109x78 2/2 (x1)

---

BH25-005 (x1)

---

BH25-006 (x1)

---

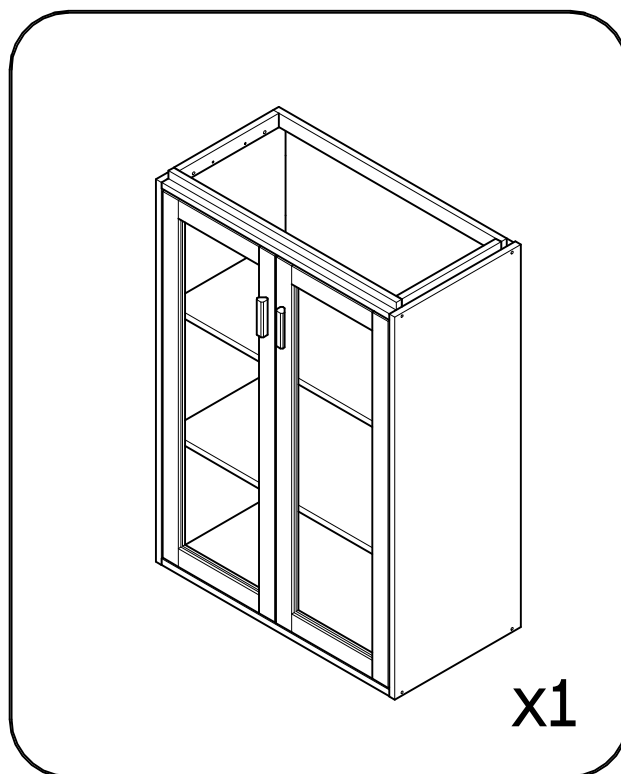

Libe 2 encimera 78 (x1)

---

BH25-014 (x1)

---

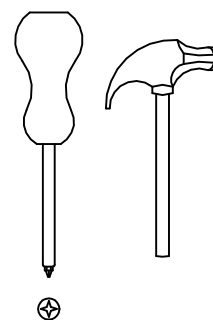
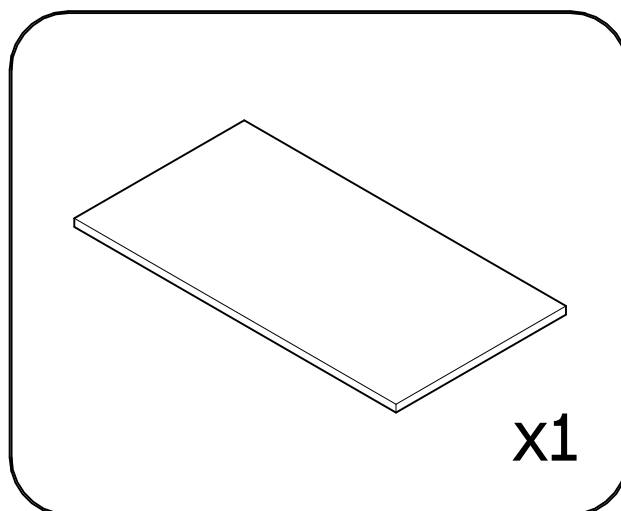

**L U F E**

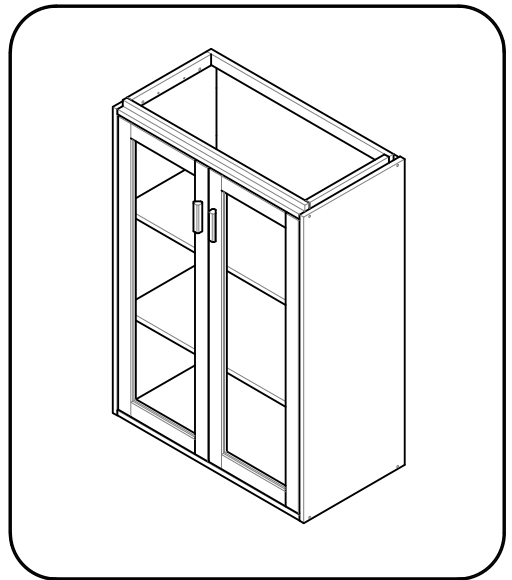

Libe 2 109x78 2/2

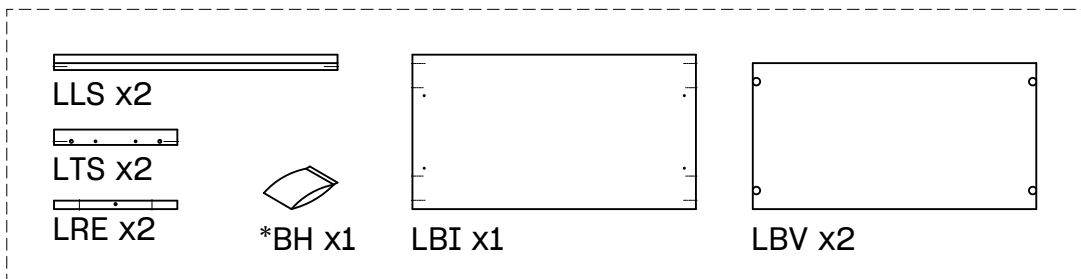

Libe 2 vitrina 1/2

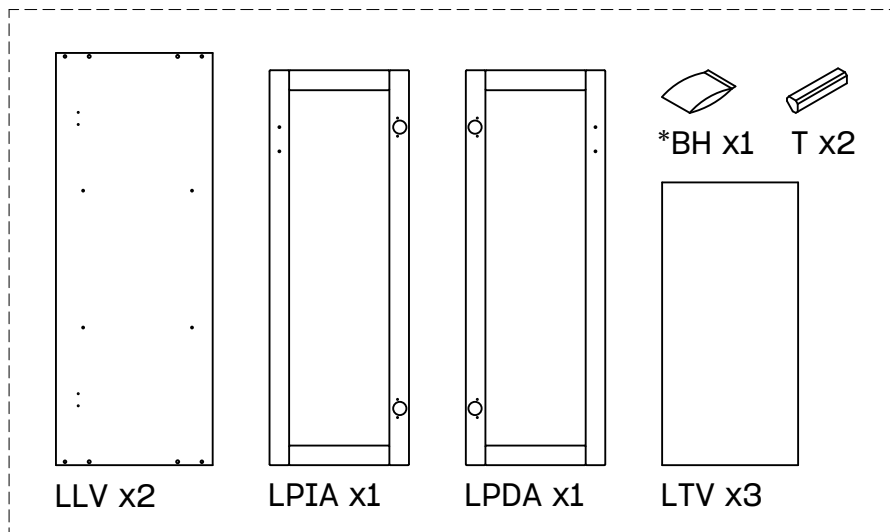

BH25-005

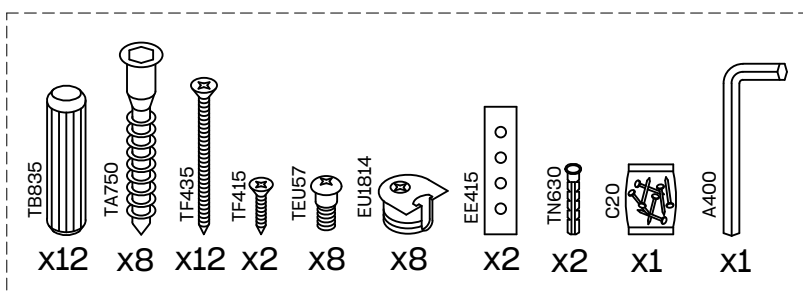

BH25-006

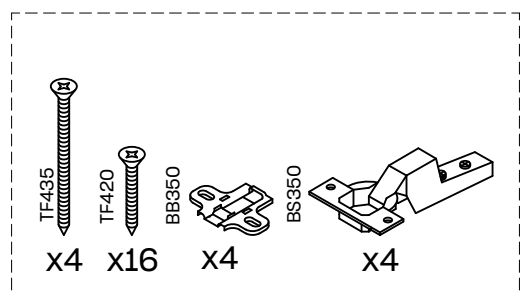

**L U F E**

1

BB360 x 4 TF-420 x 8 TEU57 x 8

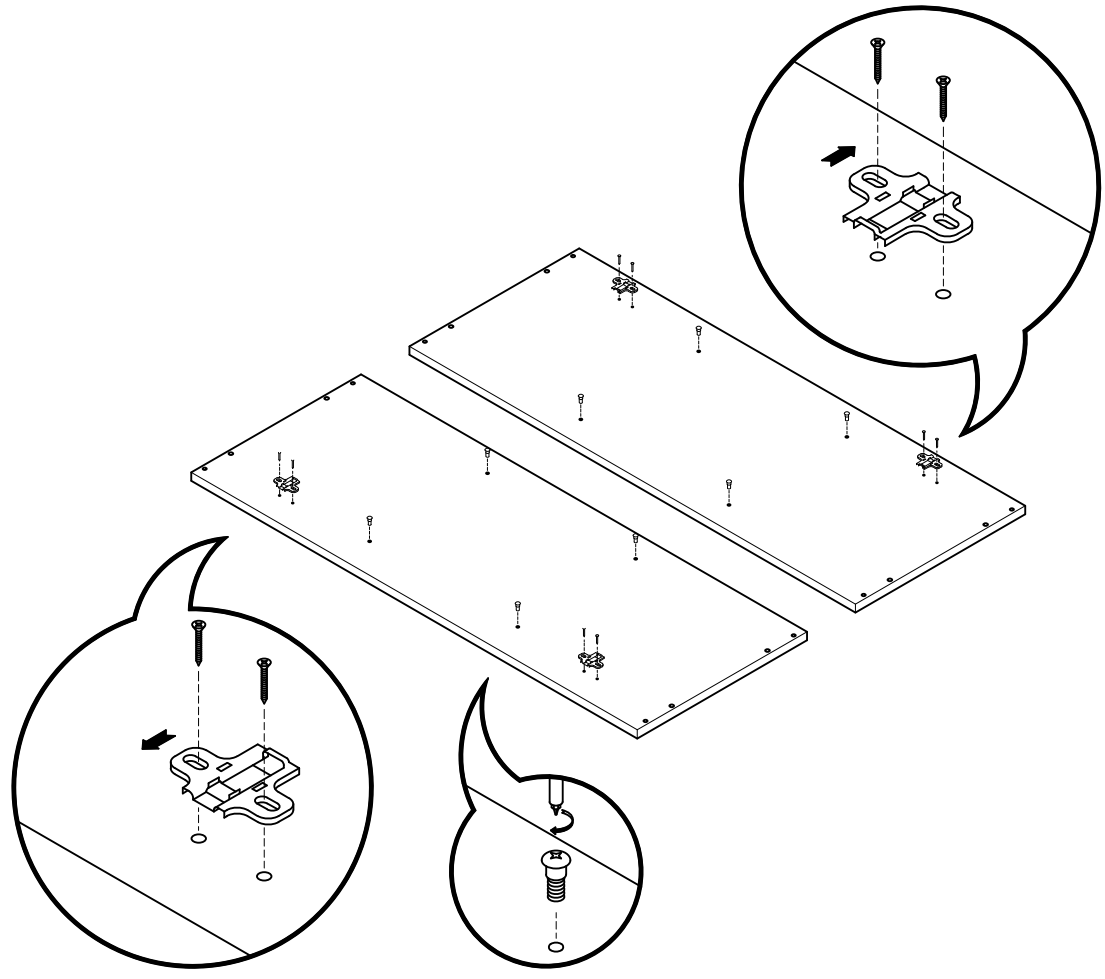

L U F E

2

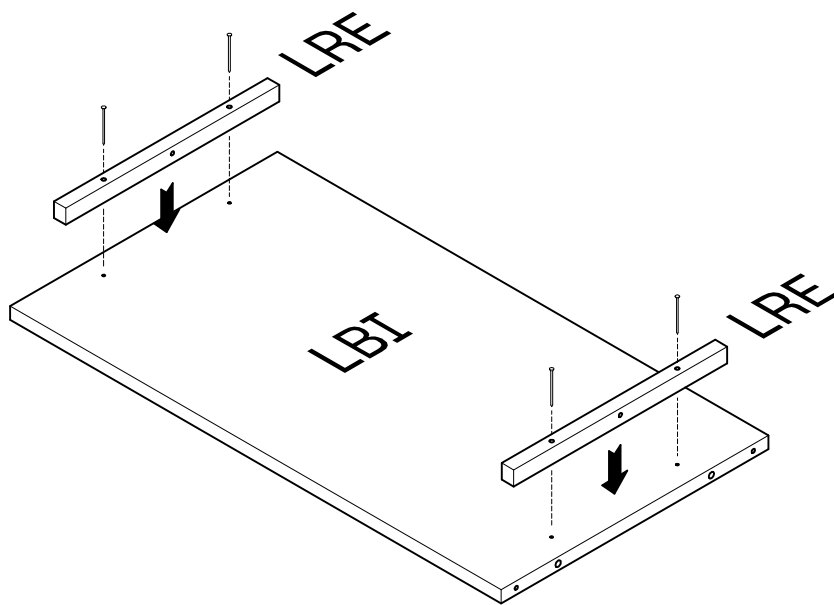
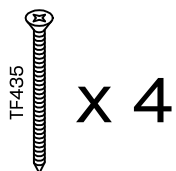

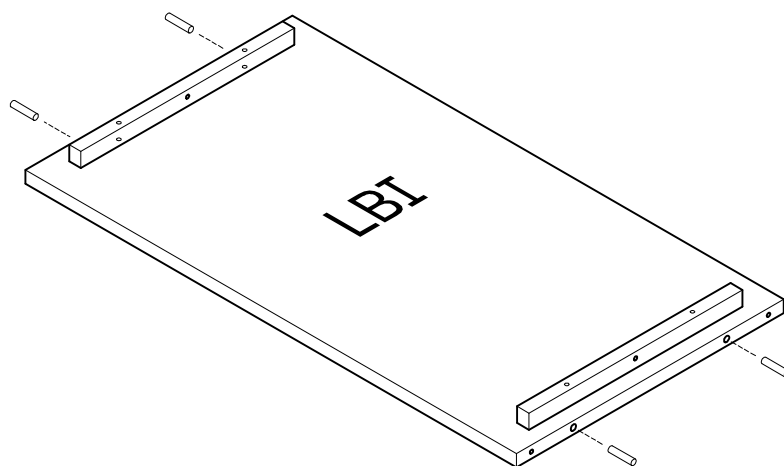
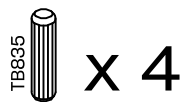

3

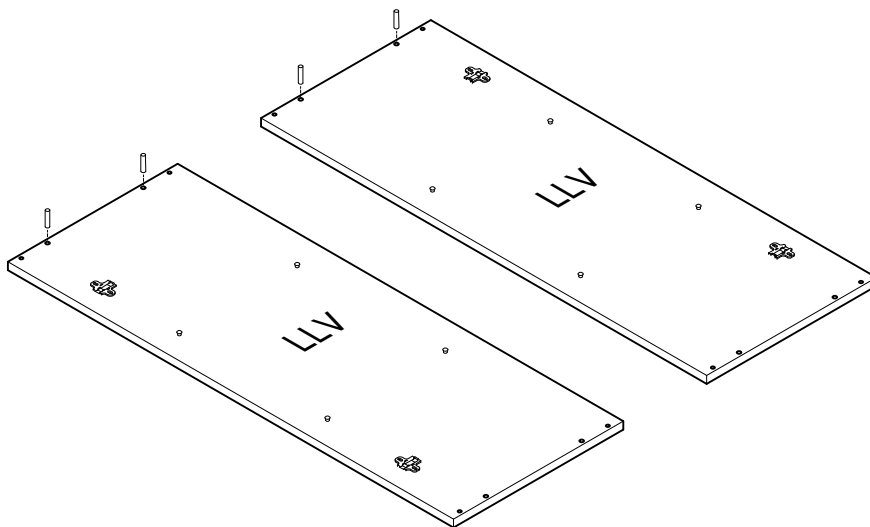

L U F E

4  x 4



5  x 4

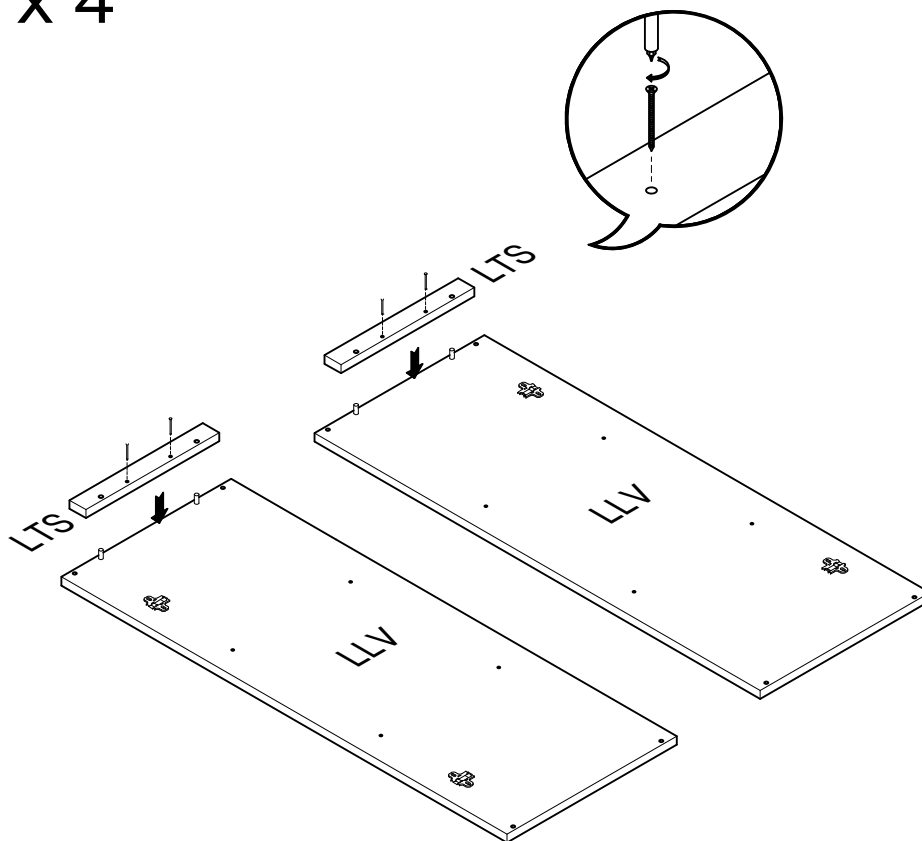

L U F E

6

TB835  
x 4

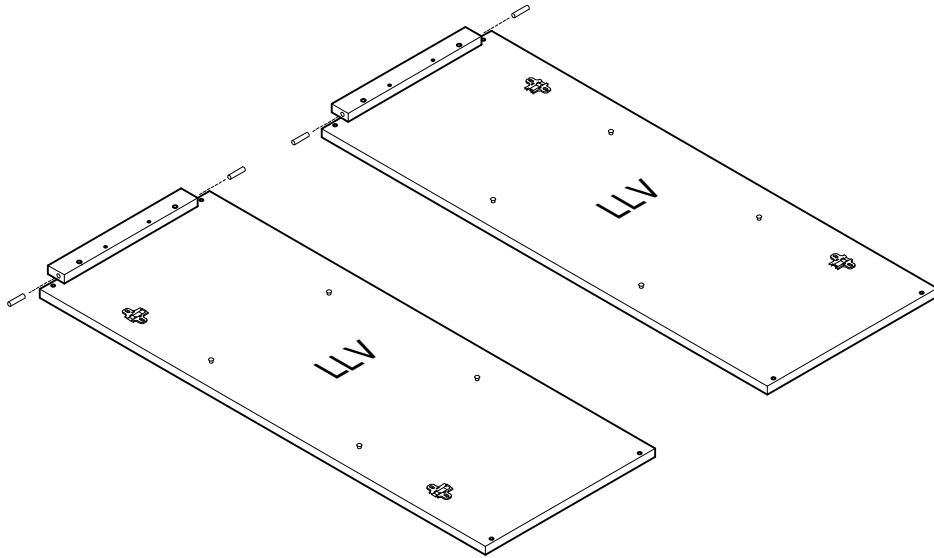

7

TA750  
x 4

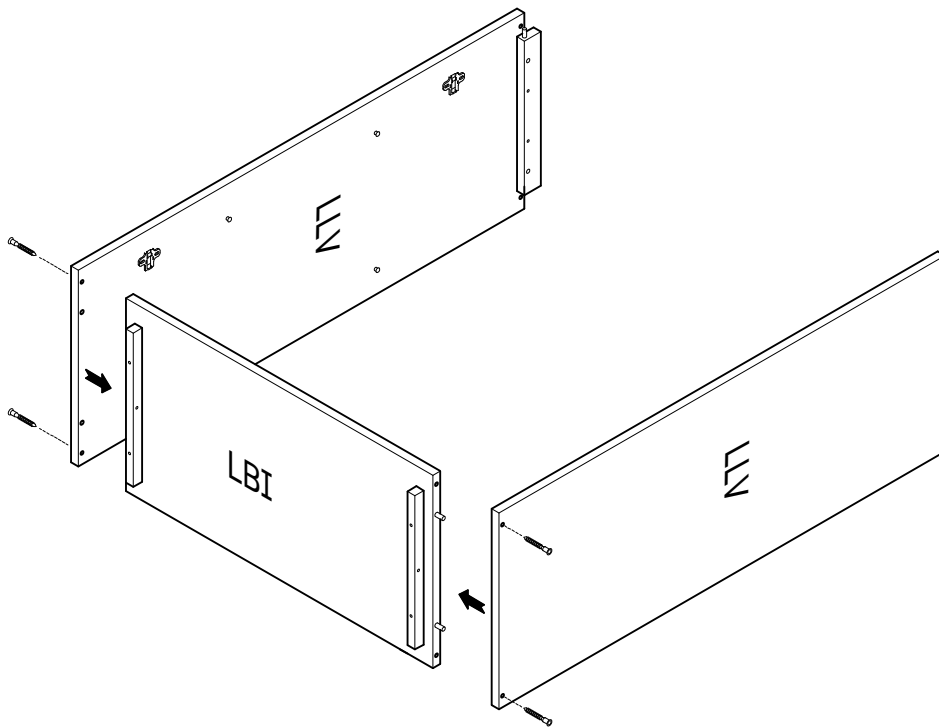

L U F E

8

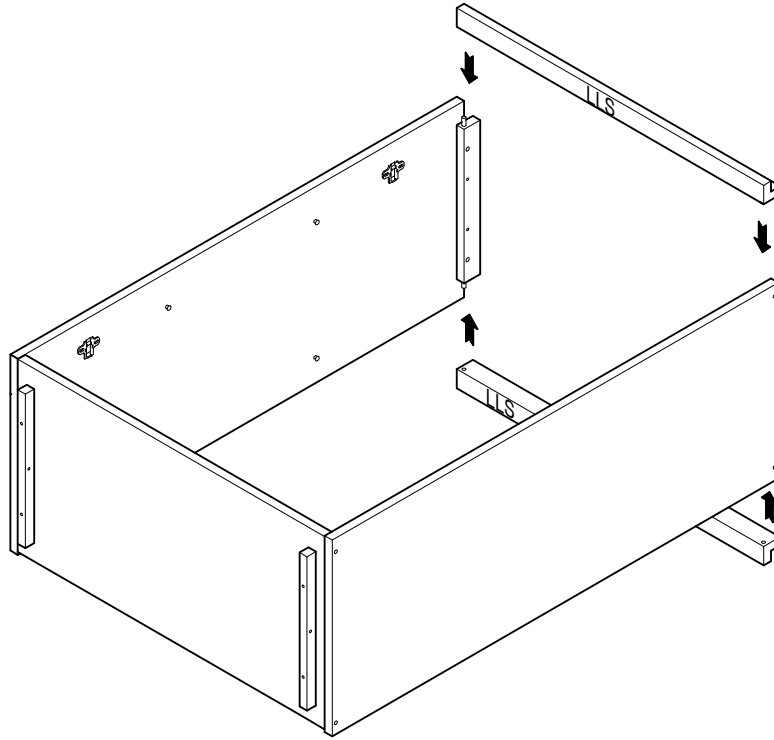

9

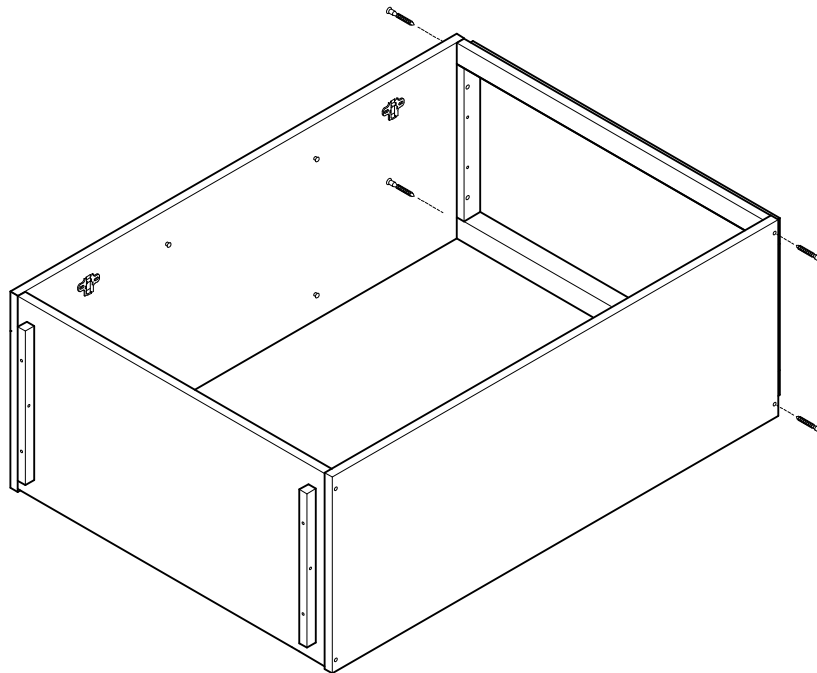
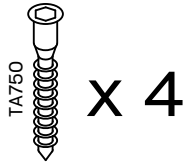

L U F E

# 10

EU1814



x 8

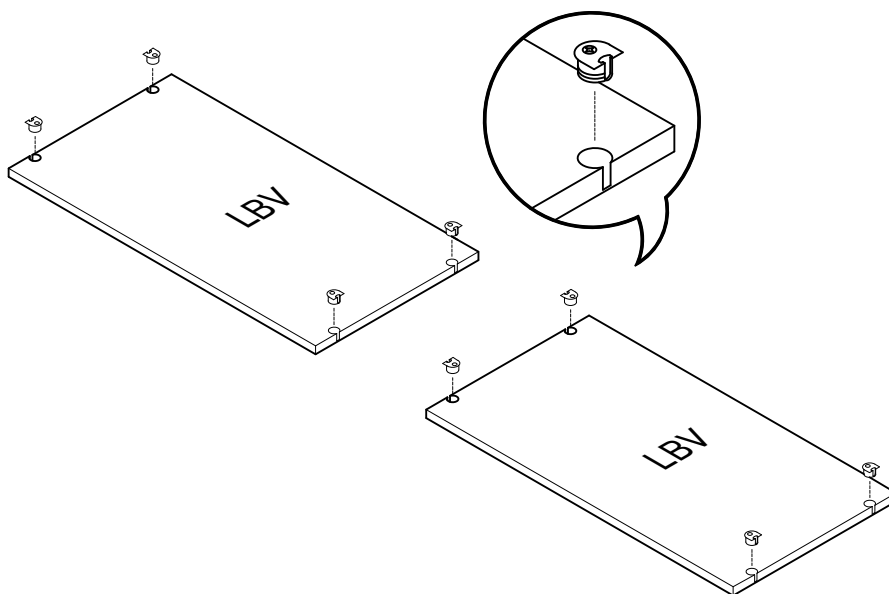

# 11

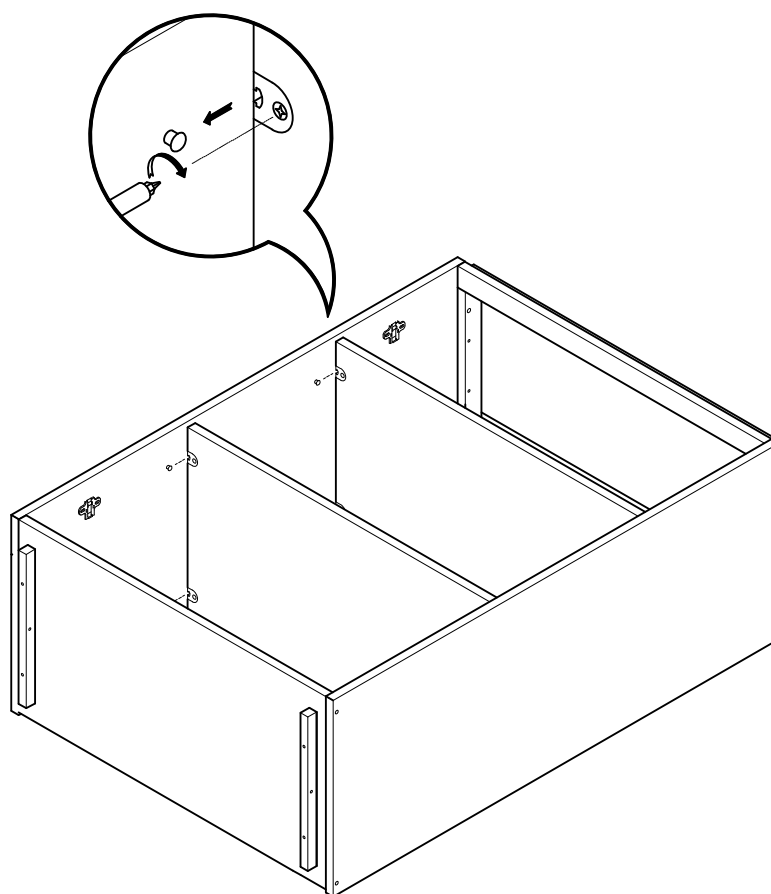

# L U F E

12

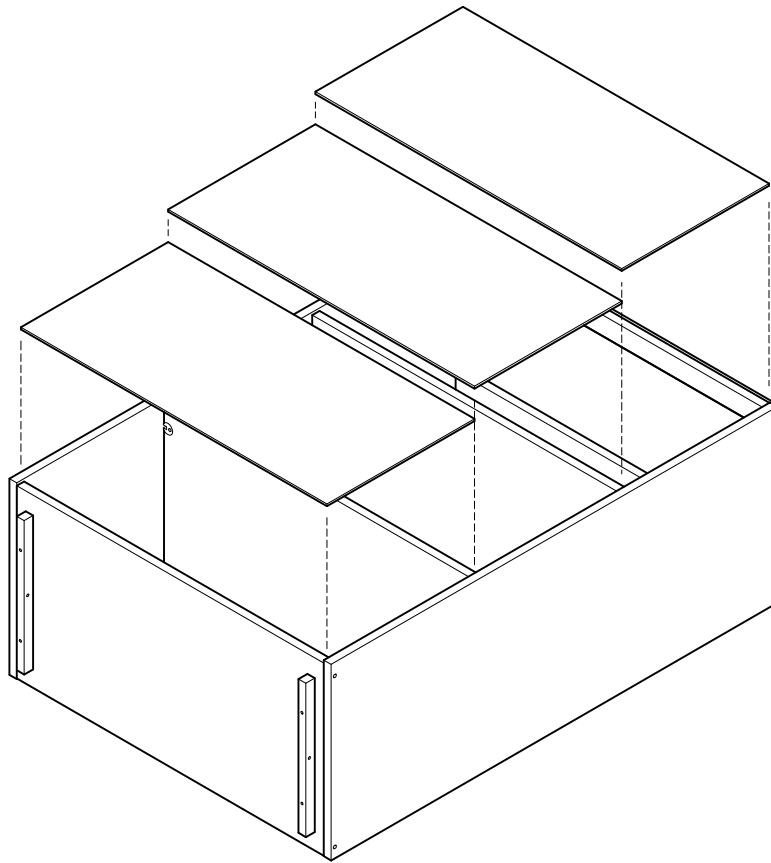

13



x 1

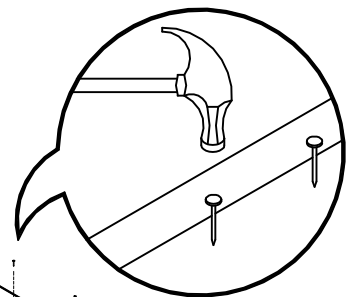
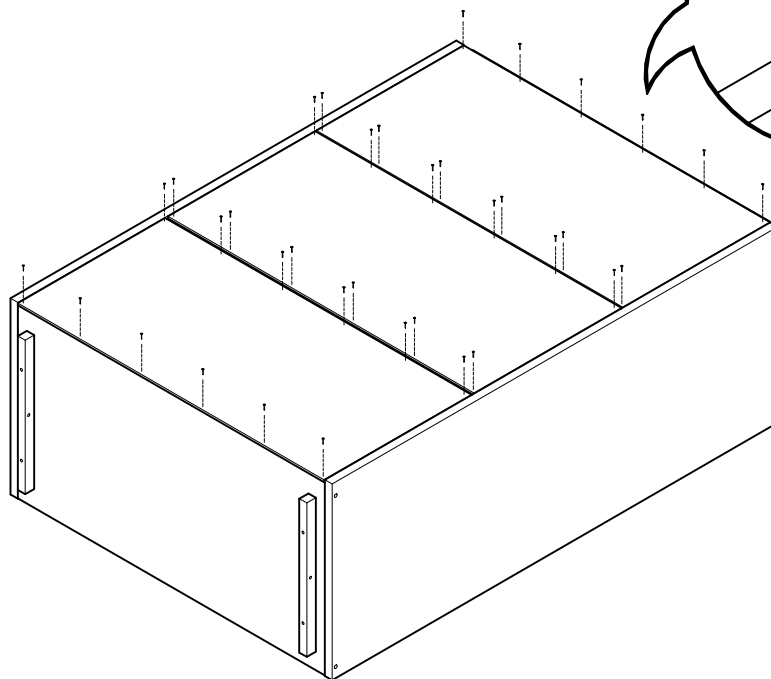

L U F E

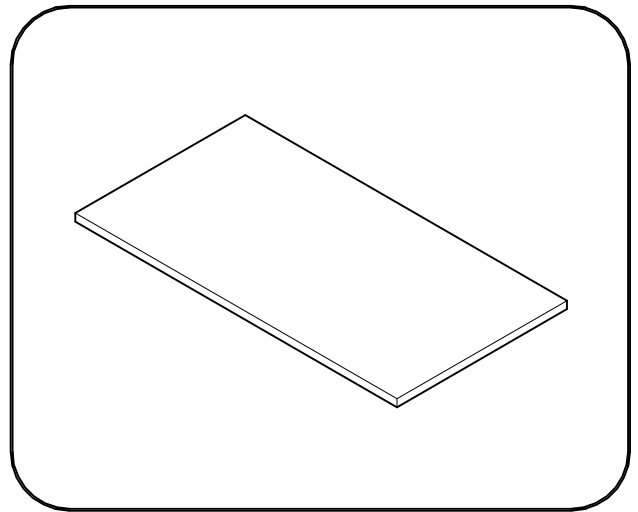

### Libe encimera corta

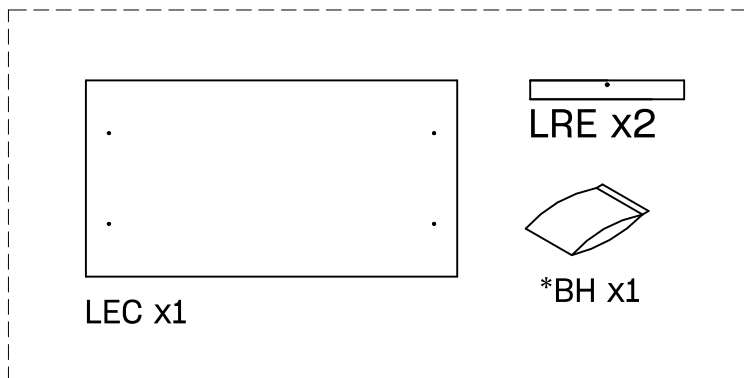

### BH25-014

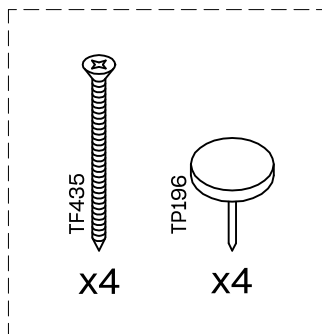

14

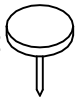
TP196  x 4

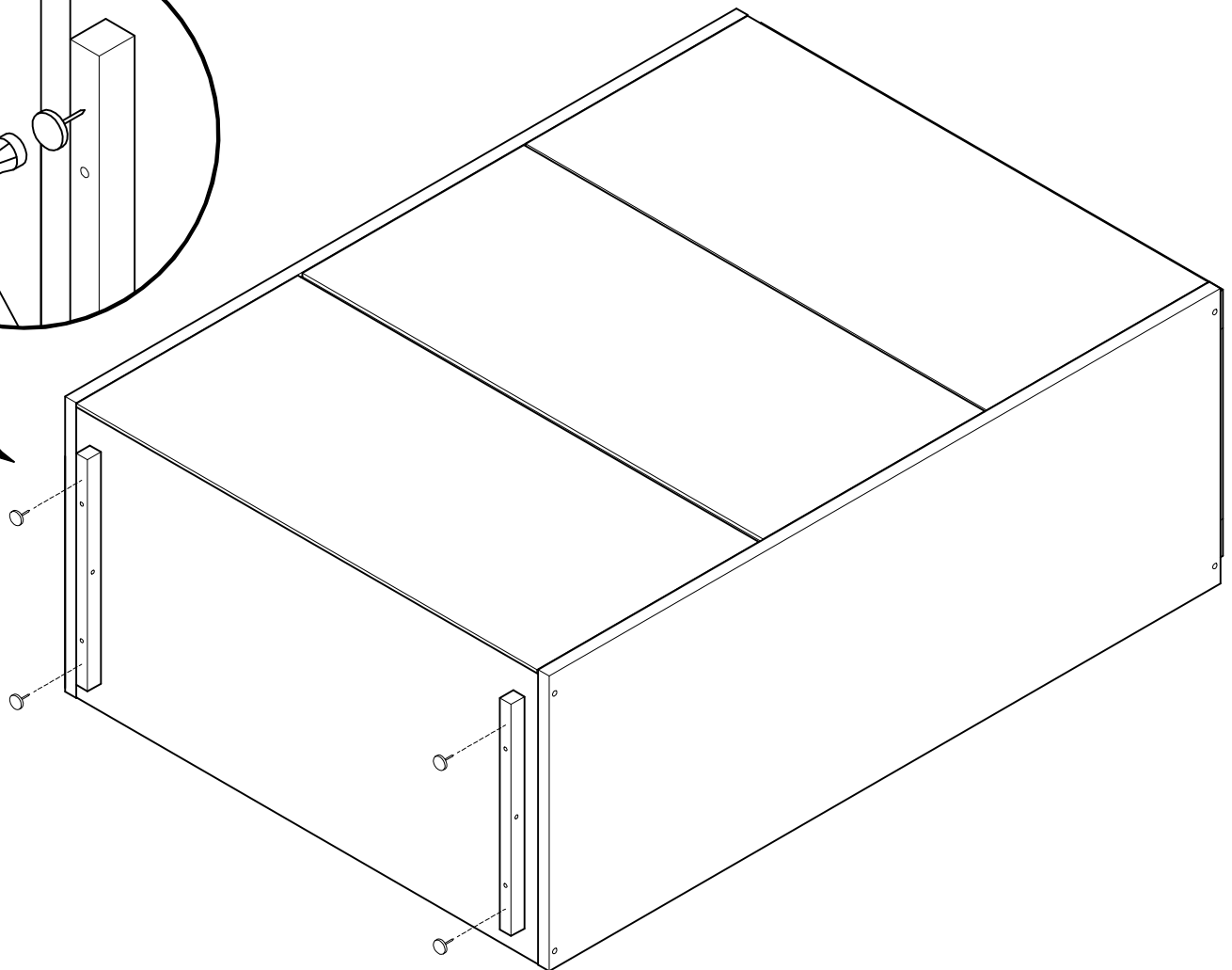
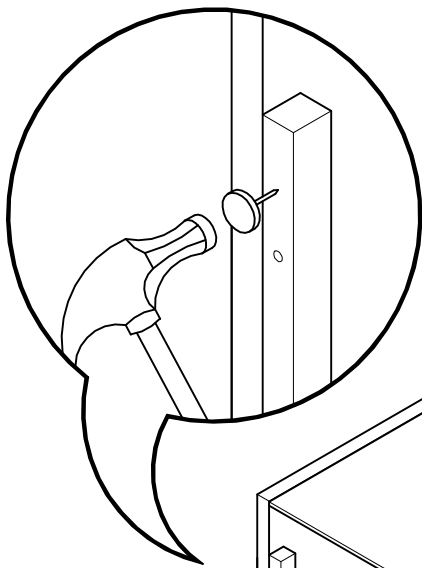

L U F E

15



x 2



x 2

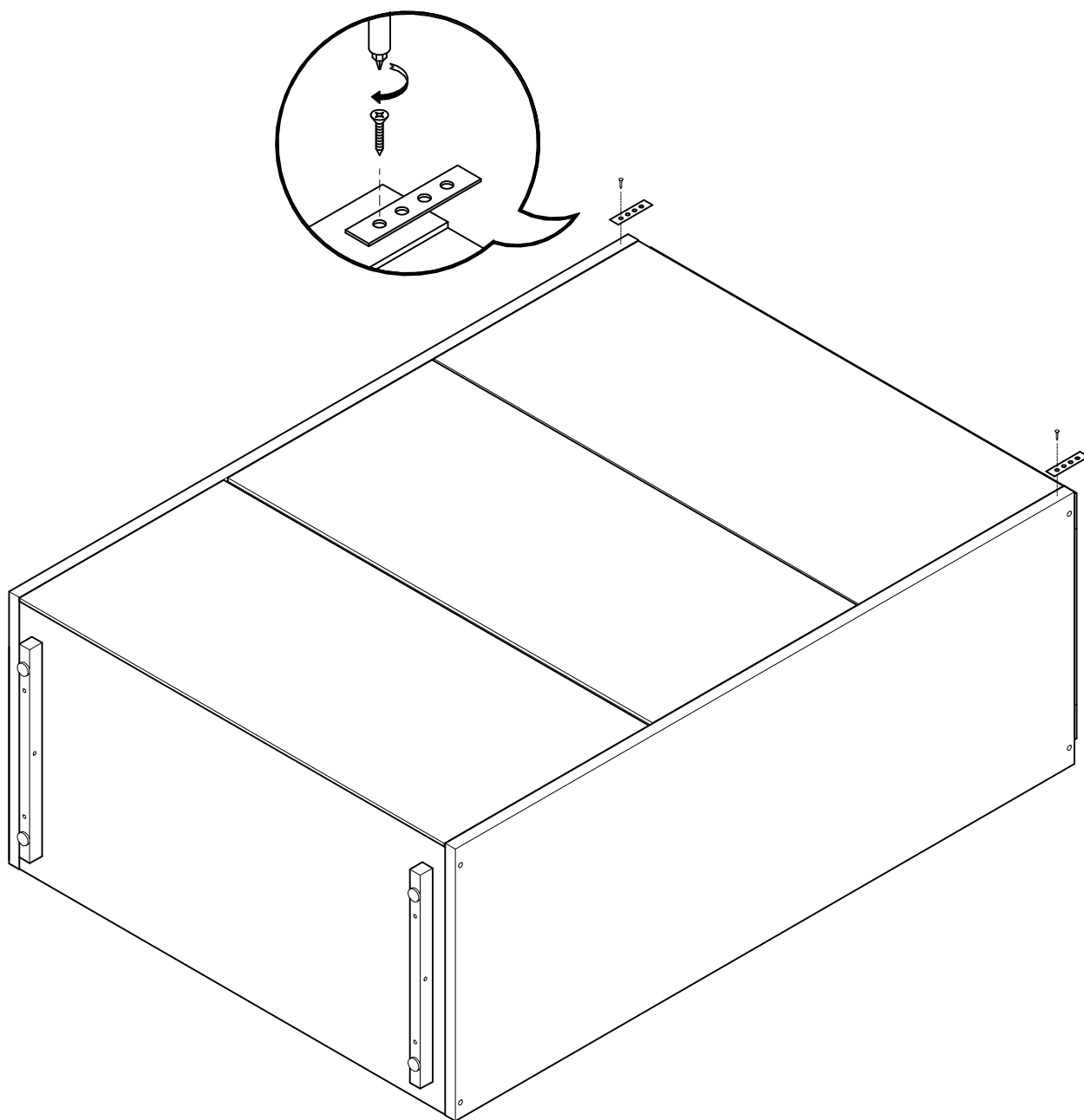

L U F E

# 16

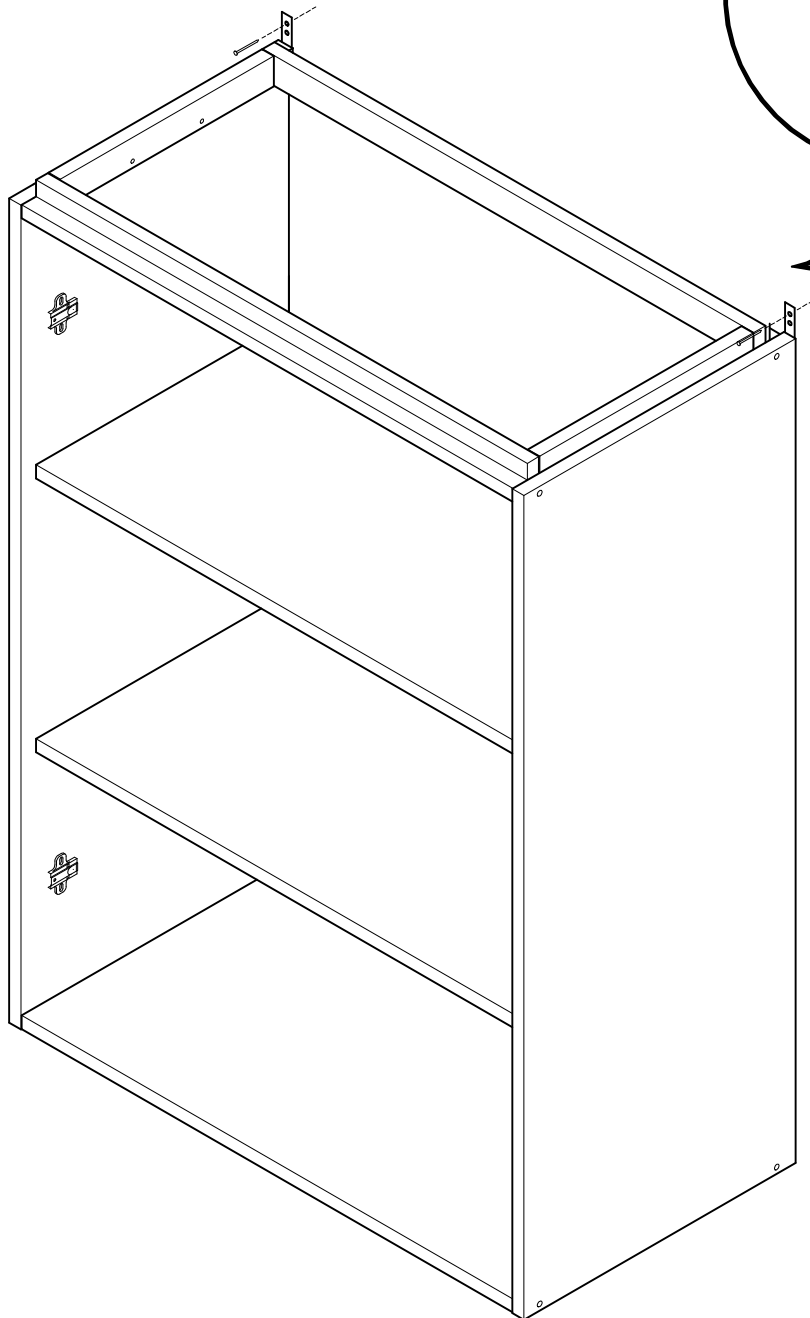
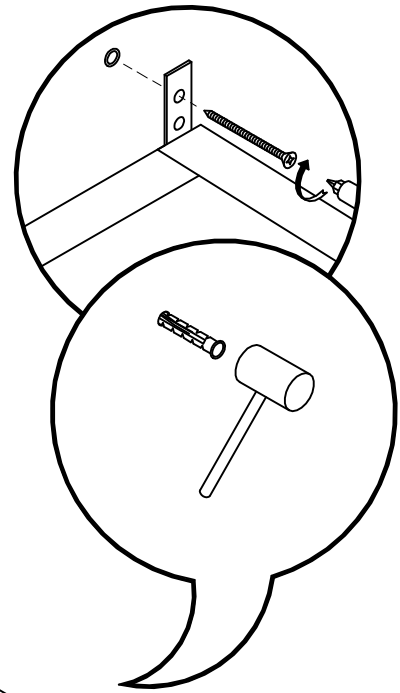
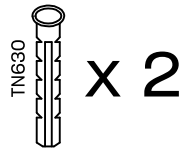
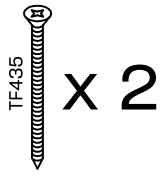

ES: Imprescindible anclar a la pared.  
FR: Ancrage au mur nécessaire.  
PT: A fixação à parede é essencial.  
IT: Indispensabile ancorare al muro.

## L U F E

17

TF435  
x 4

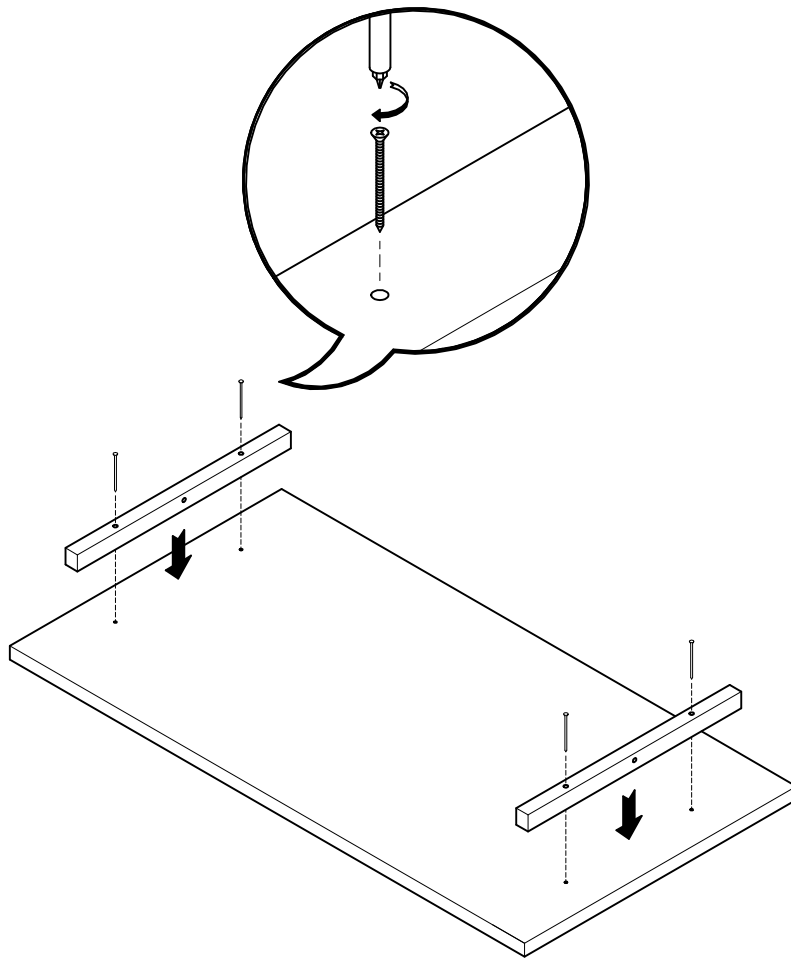

L U F E

18

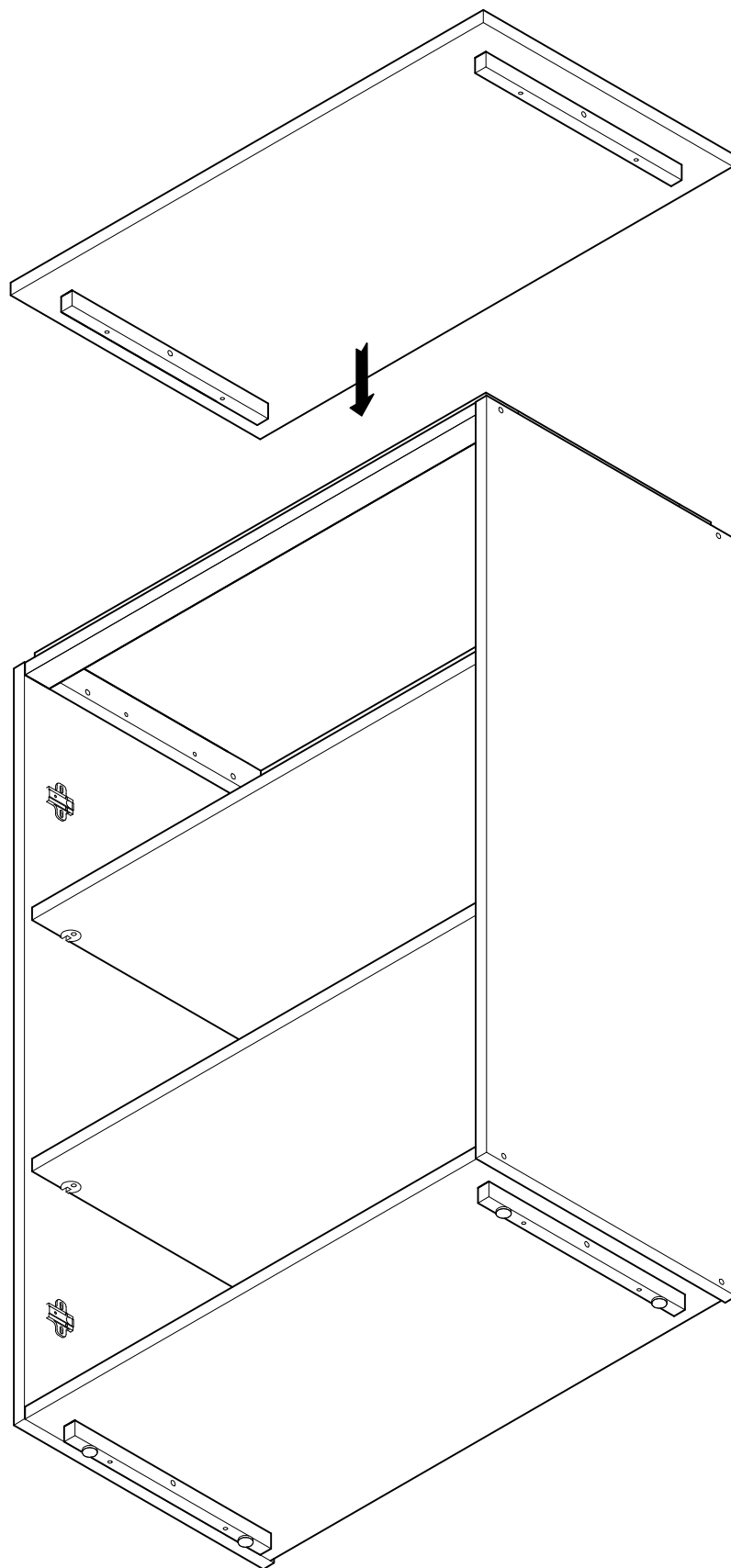

L U F E

19

TF435  
x 2

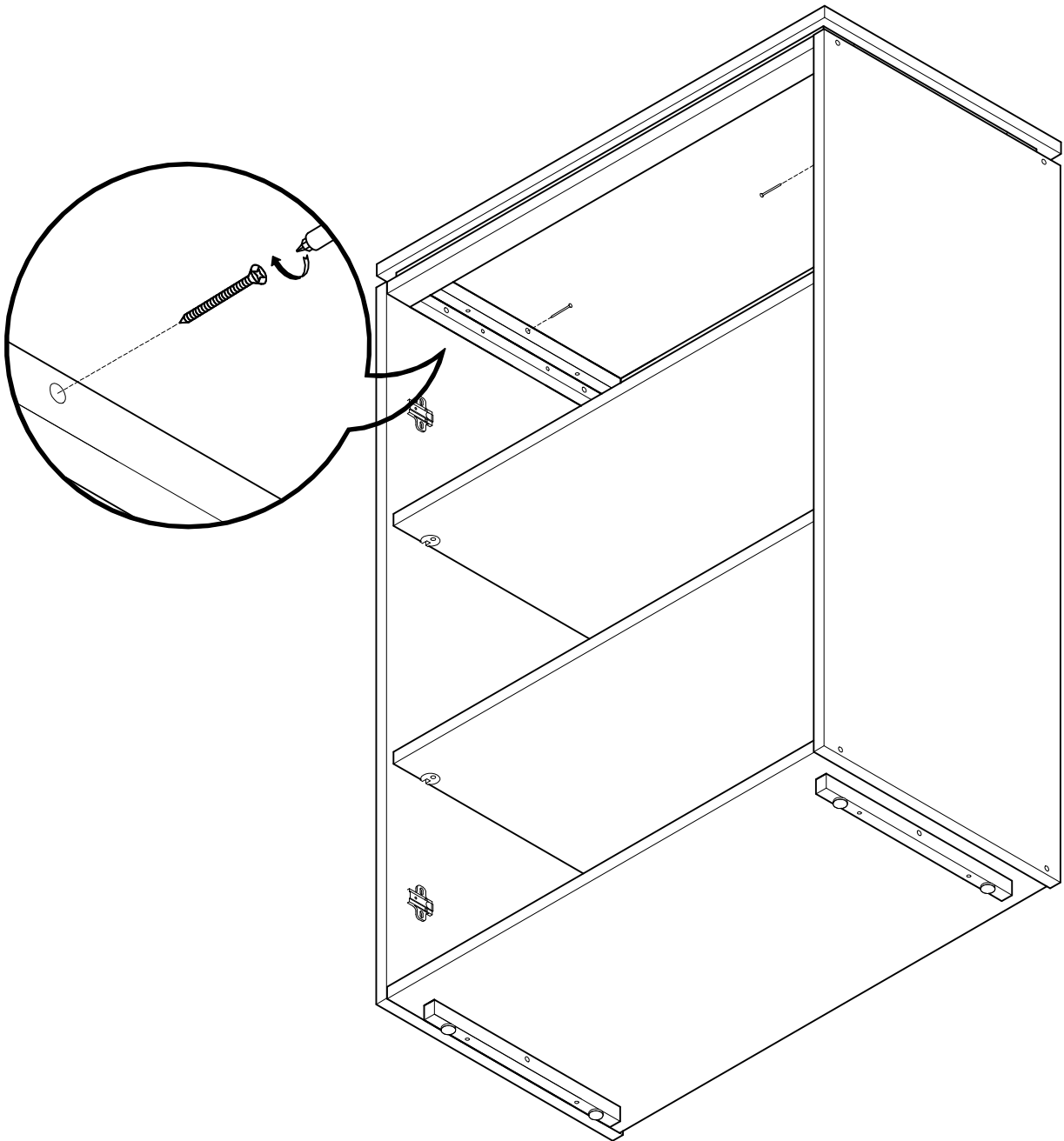

L U F E

20

BS350

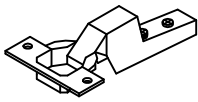

x 4



x 8

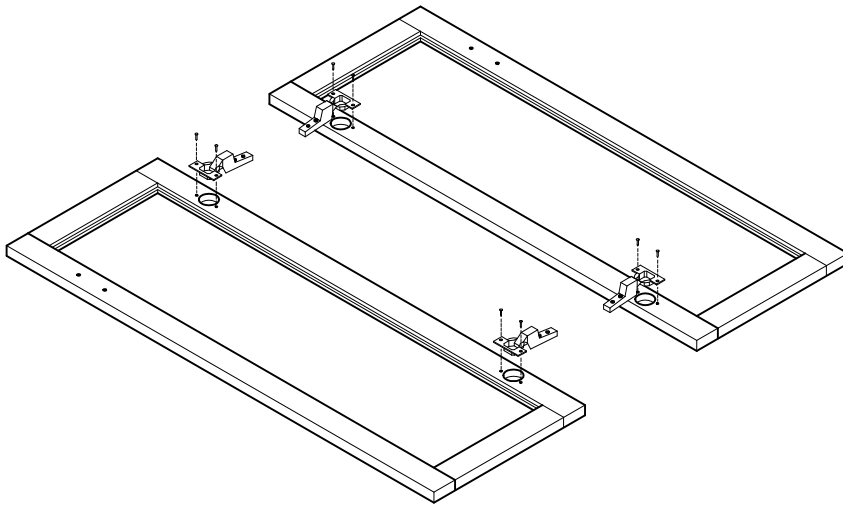

21



x 4

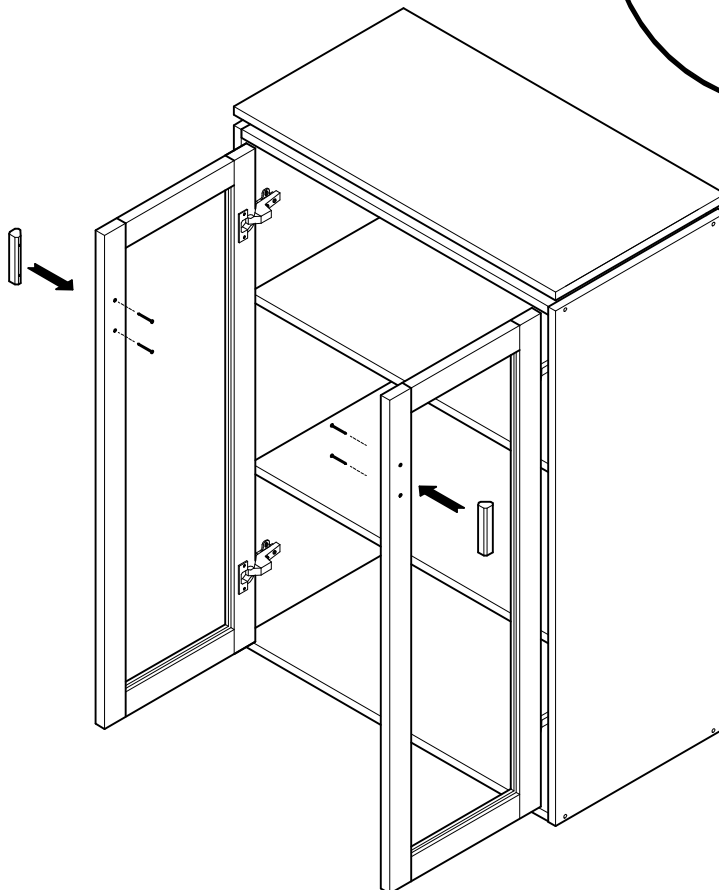
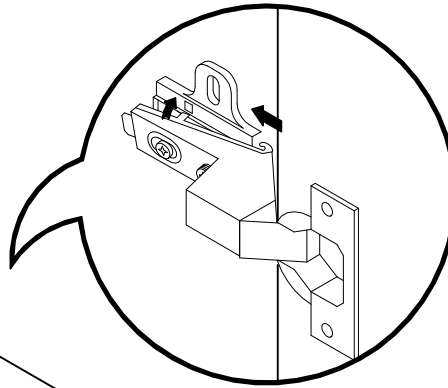

L U F E

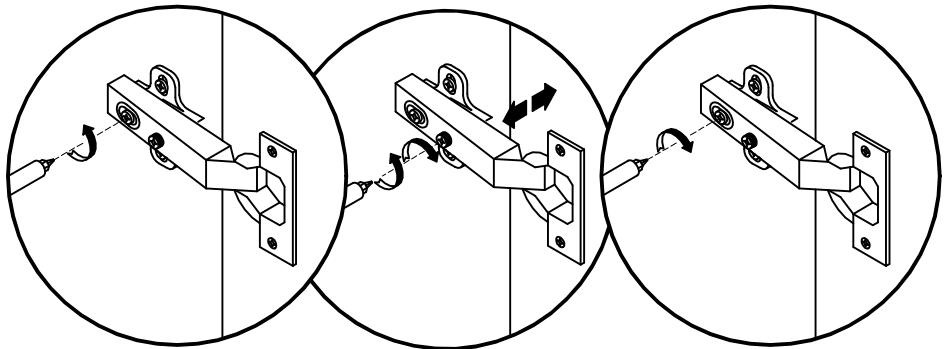
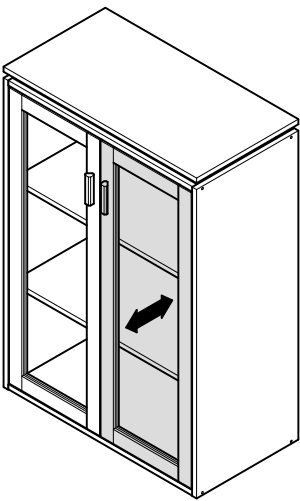
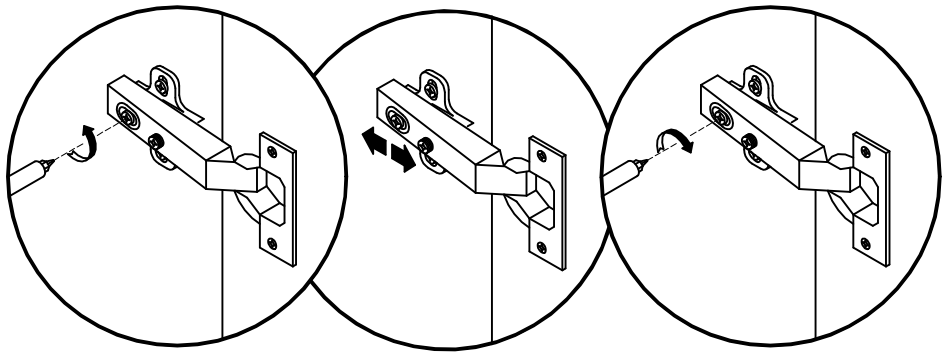
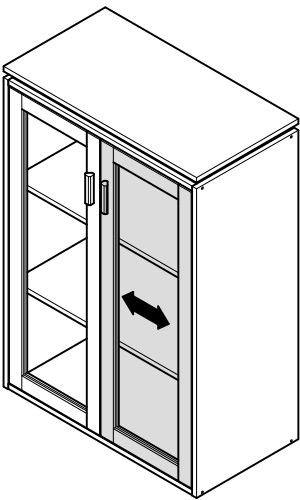
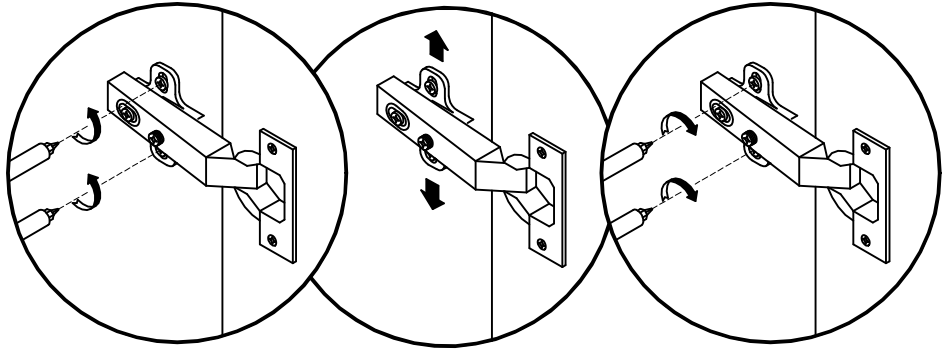
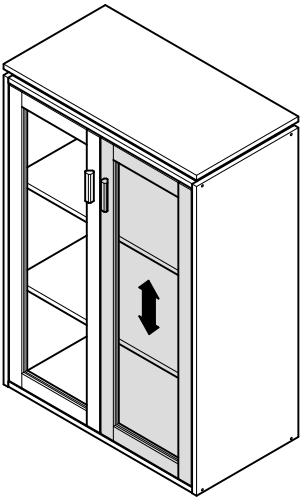

L U F E

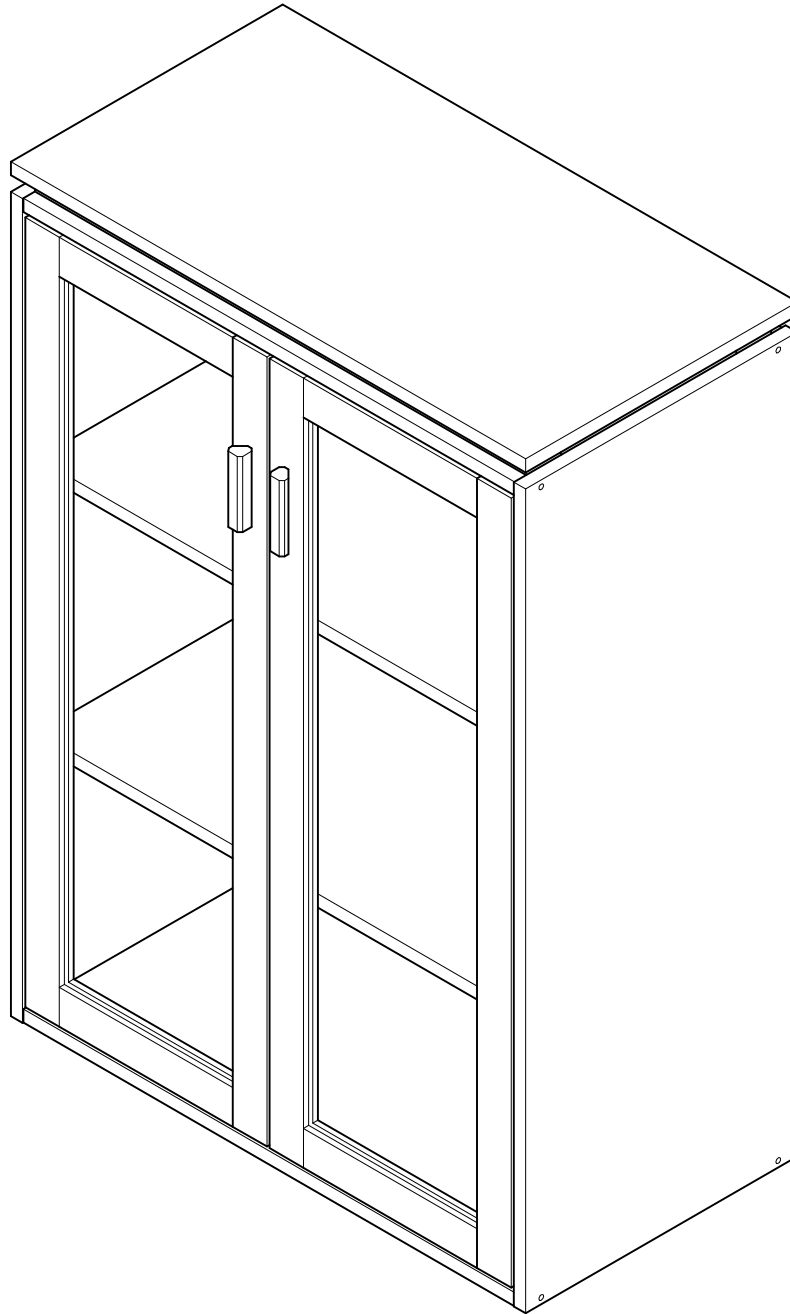

**L U F E**

ESPAÑA  
muebleslufe.com  
@muebleslufe

FRANCE / BELGIQUE  
meubleslufe.fr  
@lufefrance

PORTUGAL  
moveislufe.pt  
@lufeportugal

ITALIA  
mobililufe.it  
@lufemobili

---

**L U F E**

TODOLUFE S.L.  
Pol. Ind. Etxezarreta 9  
20749 Aizarnazabal (Gipuzkoa)

(+34) 943 810 795  
info@muebleslufe.com