

MEZANINA

cama alta 90
lit haut 90
cama alta 90
letto a soppalco 90

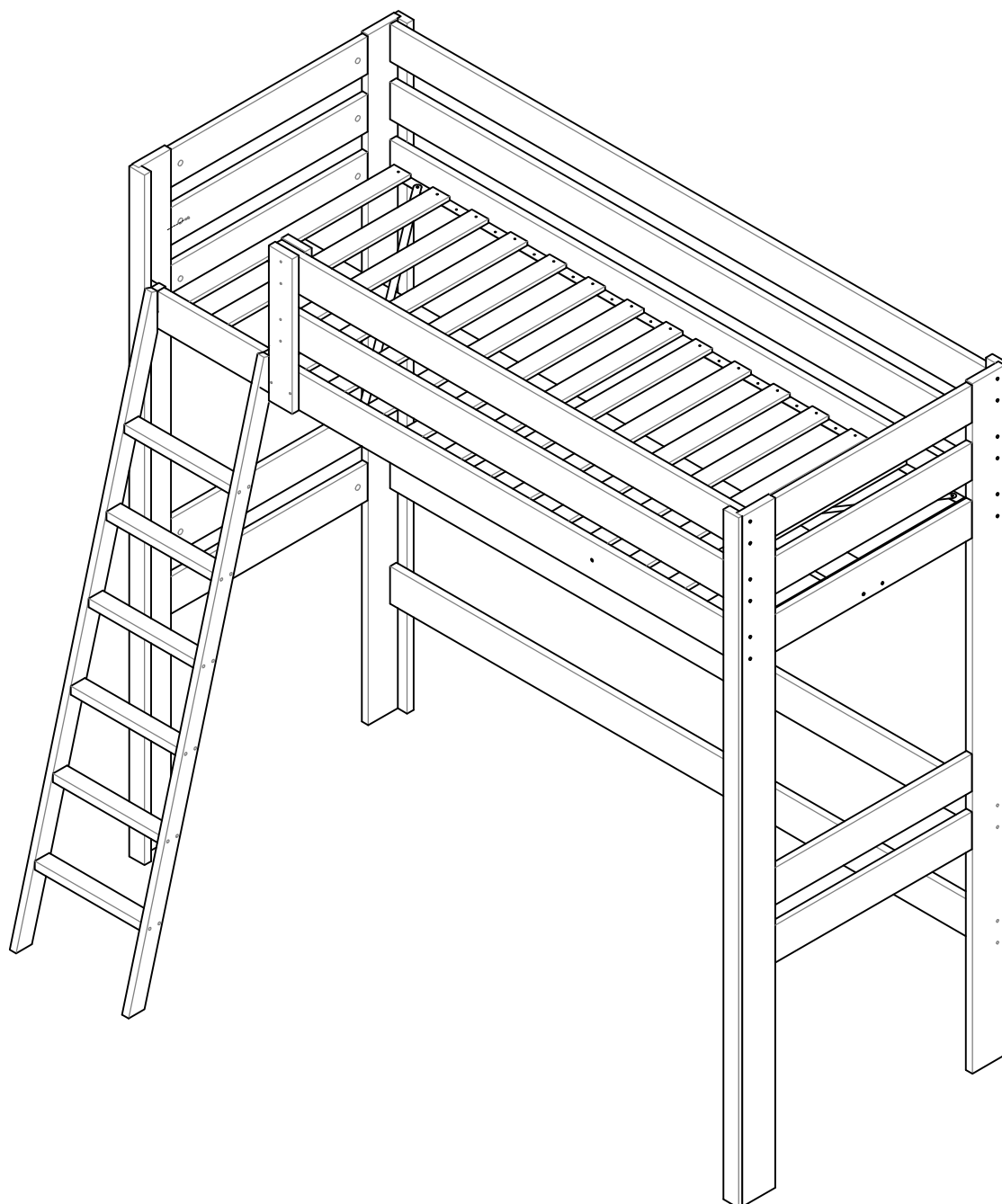

L U F E



IMPORTANTE: LEA LAS INSTRUCCIONES DETENIDAMENTE Y CONSÉRVELAS PARA CONSULTAS POSTERIORES.

- . ADVERTENCIA: Las camas altas y la cama superior de una litera, no son adecuadas para niños menores de seis años, debido al riesgo de lesiones por caída.
- . ADVERTENCIA: Las literas y las camas altas pueden presentar un riesgo grave de estrangulamiento si no se utilizan correctamente. No se debe sujetar o colgar en ninguna parte de la litera, ningún elemento que no esté diseñado para utilizarlo como la cama. Por ejemplo: (pero puede haber otros) cuerdas, cordeles, cordones, ganchos, correas y bolsas.
- . ADVERTENCIA: Los niños pueden quedar atrapados entre la cama y la pared. Para evitar el riesgo de lesiones graves, la distancia entre la barrera de seguridad superior y la pared sea inferior a 75mm o superior a 230mm.
- . Es conveniente ajustar correctamente los elementos de fijación y comprobar que no se desajustan.
- . Se recomienda que la litera no se utilice si alguno de sus componentes estructurales está roto o falta.
- . Es necesario que la habitación esté ventilada para mantener una humedad baja e impedir la formación de moho en la cama y sus alrededores.
- . Es conveniente revisar periódicamente que todos los elementos de fijación están correctamente ajustados.
- . El grosor máximo del colchón superior es de 210mm.
- . Seguir siempre las instrucciones del fabricante.
- . Esta litera cumple los requisitos de seguridad según la norma UNE EN 747:2012-1+A1:2015.



IMPORTANT: LISEZ ATTENTIVEMENT LES INSTRUCTIONS ET CONSERVEZ-LES POUR RÉFÉRENCE ULTÉRIEURE.

- . AVERTISSEMENT: Les lits mezzanines et le lit superposé du haut ne conviennent pas aux enfants de moins de six ans, en raison du risque de blessures en cas de chute.
- . AVERTISSEMENT: Les lits superposés et les lits mezzanines peuvent présenter un risque sérieux d'étranglement s'ils ne sont pas utilisés correctement. Ne pas fixer ni accrocher sur aucune partie du lit, tout élément qui n'est pas conçu pour être utilisé comme lit. Par exemple: (mais il peut y en avoir d'autres) cordes, ficelles, cordons, crochets, sangles et sacs.
- . AVERTISSEMENT: Les enfants peuvent se retrouver coincés entre le lit et le mur. Pour éviter tout risque de blessure grave, la distance entre la barrière de sécurité supérieure et le mur ne doit pas dépasser 75mm ou doit être supérieure à 230mm.
- . Il convient d'ajuster correctement les éléments de fixation et de vérifier qu'ils ne sont pas déréglés.
- . Il est recommandé de ne pas utiliser le lit superposé si l'un de ses composants structurels est cassé ou manquant.
- . La pièce doit être ventilée pour maintenir un faible taux d'humidité et empêcher la formation de moisissures dans et autour du lit.
- . Il est conseillé de vérifier périodiquement que tous les éléments de fixation sont correctement serrés.
- . L'épaisseur maximale du matelas supérieur est de 210mm.
- . Suivez toujours les instructions du fabricant.
- . Cette couchette est conforme aux exigences de sécurité de la norme UNE EN 747:2012-1+A1:2015.



IMPORTANTE: LEIA ATENTAMENTE AS INSTRUÇÕES E GUARDE-AS PARA REFERÊNCIA POSTERIOR.

- . AVISO: As camas loft e o beliche superior não são adequados para crianças menores de seis anos, devido ao risco de lesões por quedas.
- . AVISO: Beliche e camas altas podem representar um sério risco de estrangulamento se não forem usados corretamente. Não prenda ou pendure em nenhuma parte do beliche, qualquer elemento que não seja projetado para ser usado como cama. Por exemplo: (mas pode haver outros) cordas, cordões, cordas, ganchos, alças e bolsas.
- . AVISO: As crianças podem ficar presas entre a cama e a parede. Para evitar o risco de ferimentos graves, a distância entre a barreira de segurança superior e a parede não deve exceder 75mm ou deve ser superior a 230mm.
- . É conveniente ajustar corretamente os elementos de fixação e verificar se não ficam desalinhados.
- . Recomenda-se que o beliche não seja utilizado se algum de seus componentes estruturais estiver quebrado ou em falta.
- . O quarto precisa ser ventilado para manter a umidade baixa e evitar a formação de mofo dentro e ao redor da cama.
- . É aconselhável verificar periodicamente se todos os elementos de fixação estão ajustados corretamente.
- . A espessura máxima do colchão superior é de 210mm.
- . Siga sempre as instruções do fabricante.
- . Este beliche atende aos requisitos de segurança de acordo com a norma UNE EN 747:2012-1+A1:2015.



IMPORTANTE: LEGGERE ATTENTAMENTE LE ISTRUZIONI E CONSERVARLE PER FUTURI RIFERIMENTI.

- . ATTENZIONE: I letti a soppalco e la parte superiore delle strutture a castello non sono adatti a bambini di età inferiore a sei anni, per il rischio di caduta.
- . ATTENZIONE: I letti a castello e i letti a soppalco possono comportare gravi rischi di strangolamento se non utilizzati correttamente. Non appendere o fissare articoli che non siano stati progettati per essere utilizzati con il letto. Ad esempio (ma ce ne possono essere altri): corde, spago, ganci, cinghie e borse.
- . ATTENZIONE: I bambini potrebbero rimanere intrappolati tra il letto e il muro. Per evitare il rischio di lesioni gravi, assicurarsi che la distanza tra la barriera di sicurezza superiore e il muro sia inferiore a 75mm o superiore a 230mm.
- . Si consiglia di regolare correttamente gli elementi di fissaggio e di verificare che non si allentino.
- . Si raccomanda di non utilizzare il letto a castello nel caso in cui uno qualsiasi dei suoi componenti strutturali sia rotto o mancante.
- . La stanza deve essere ventilata per mantenere un basso livello di umidità ed evitare la formazione di muffa dentro e intorno al letto.
- . Si consiglia di verificare periodicamente che tutti gli elementi di fissaggio siano correttamente serrati.
- . Lo spessore massimo del materasso superiore è di 210mm.
- . Seguire sempre le istruzioni del produttore.
- . Questo letto a castello è conforme alla norma di sicurezza UNE EN 747:2012-1+A1:2015.

Cama alta 90 (1/3)

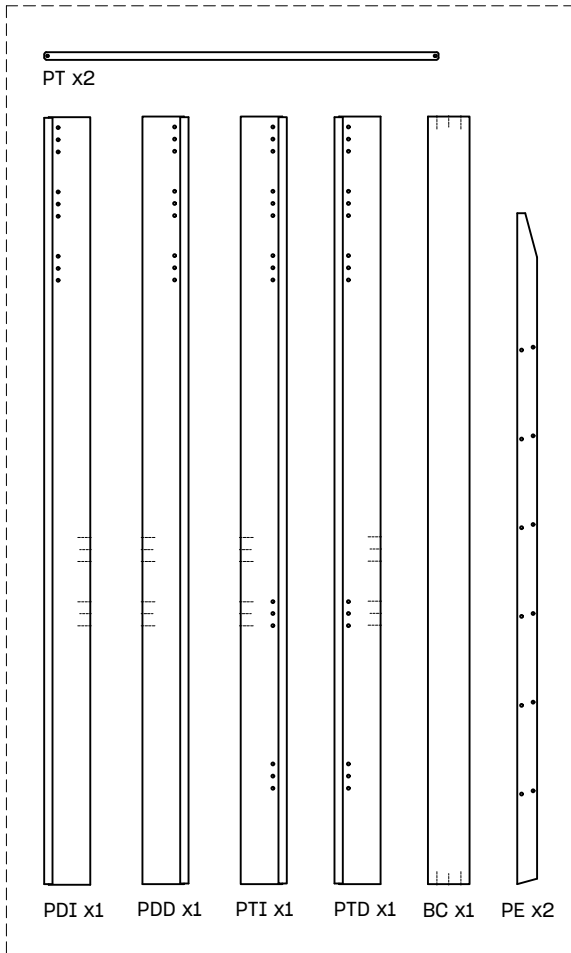

Cama alta (2/3)

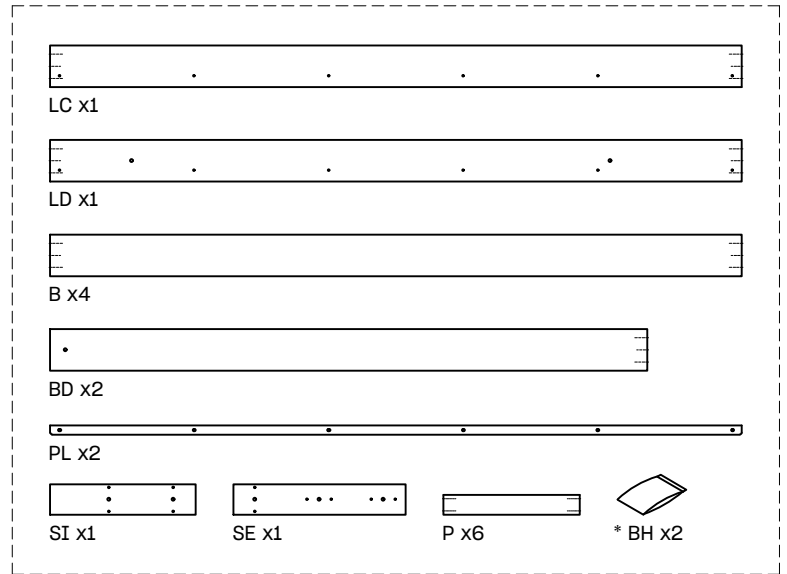

Cama alta 90 (3/3)

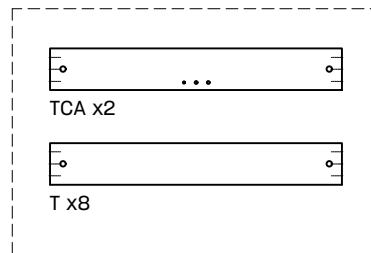

*** BH24-016**

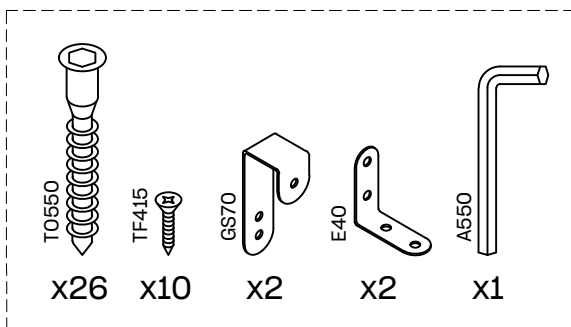

Lamas Dut 90x200

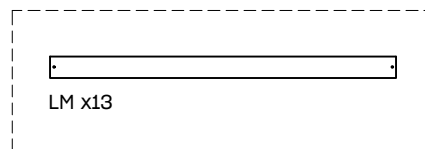

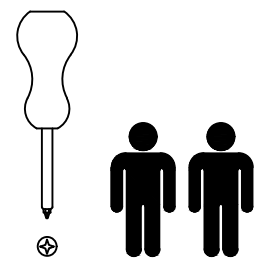
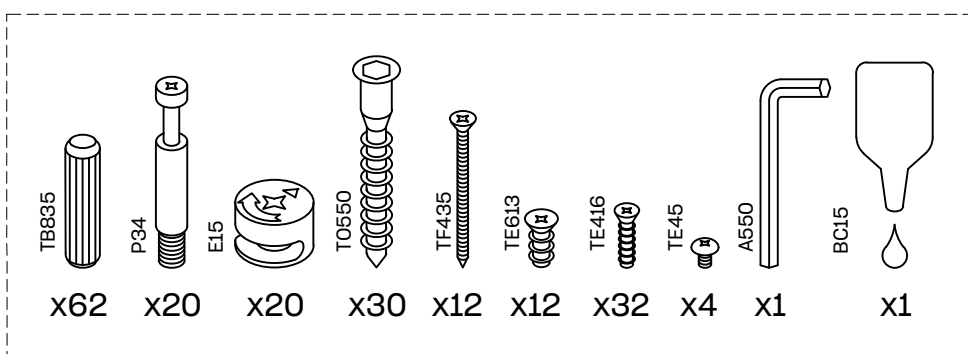

*** BH24-015**

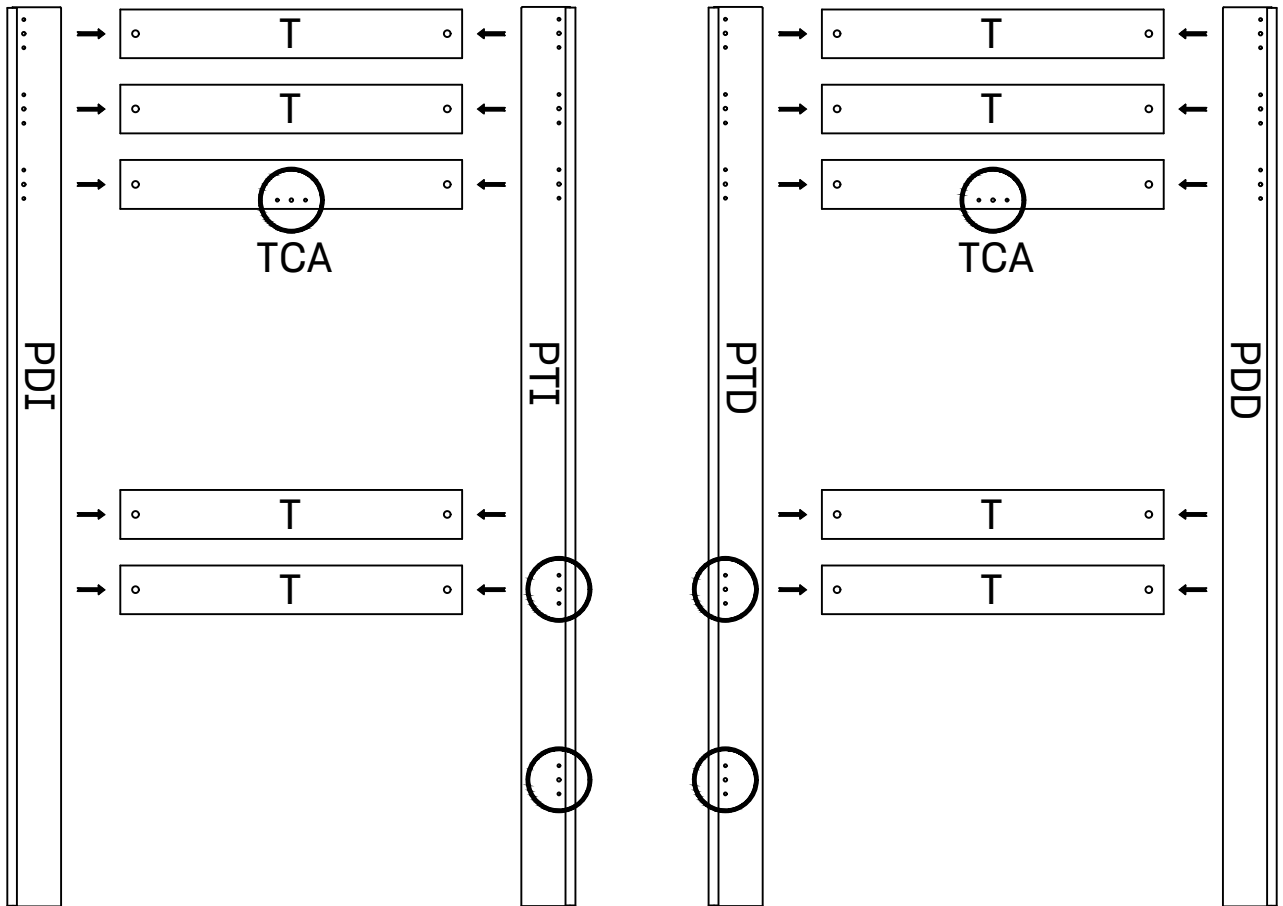

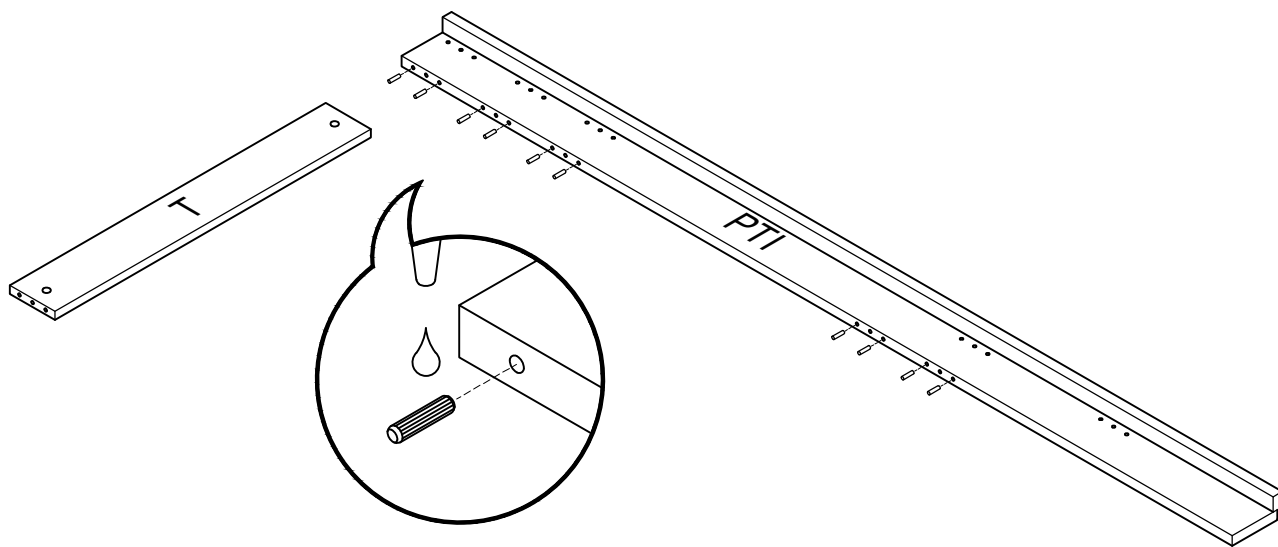
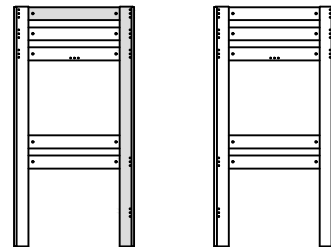

1  x 10  x 10



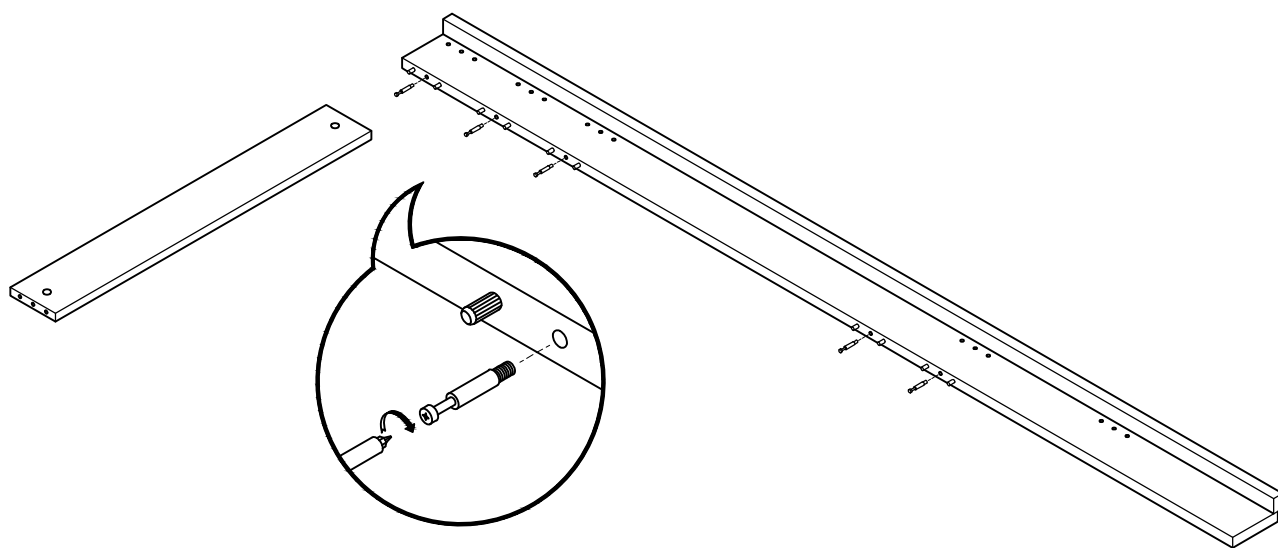
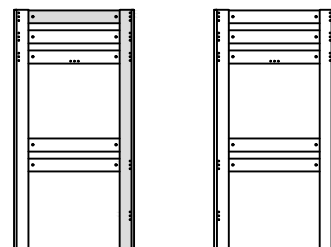

2  x 5

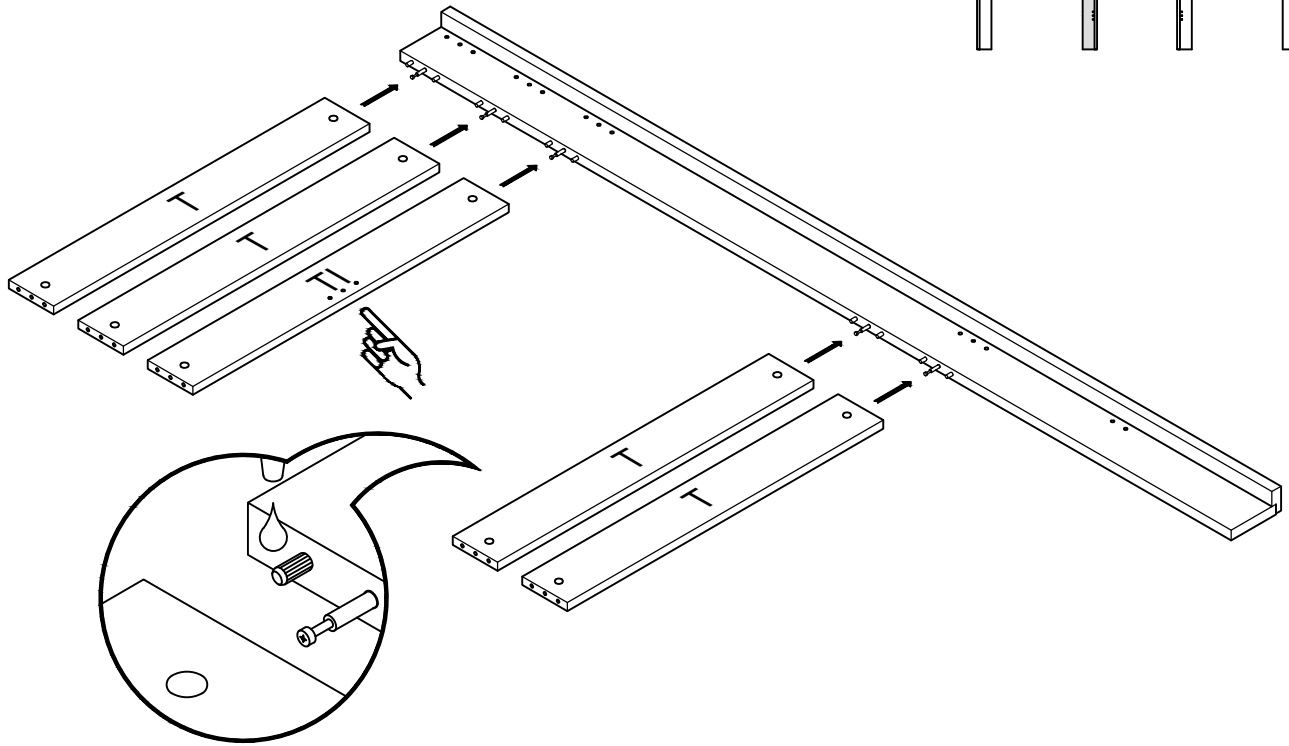
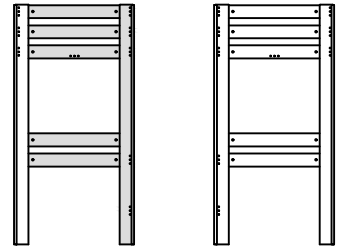

L U F E

3  x 10



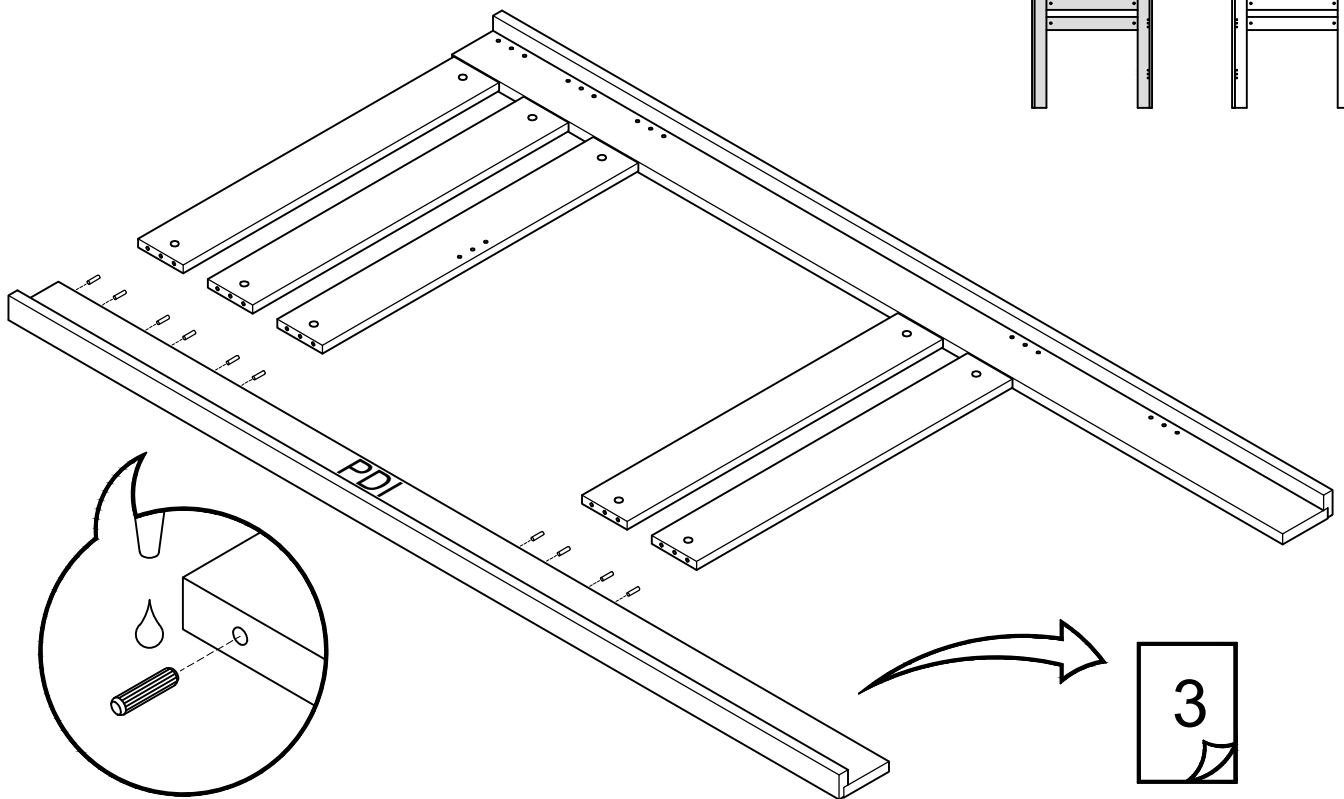
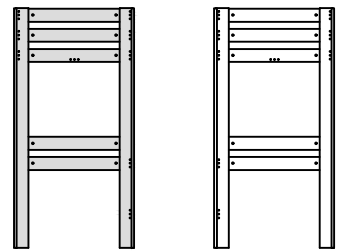

4  x 10

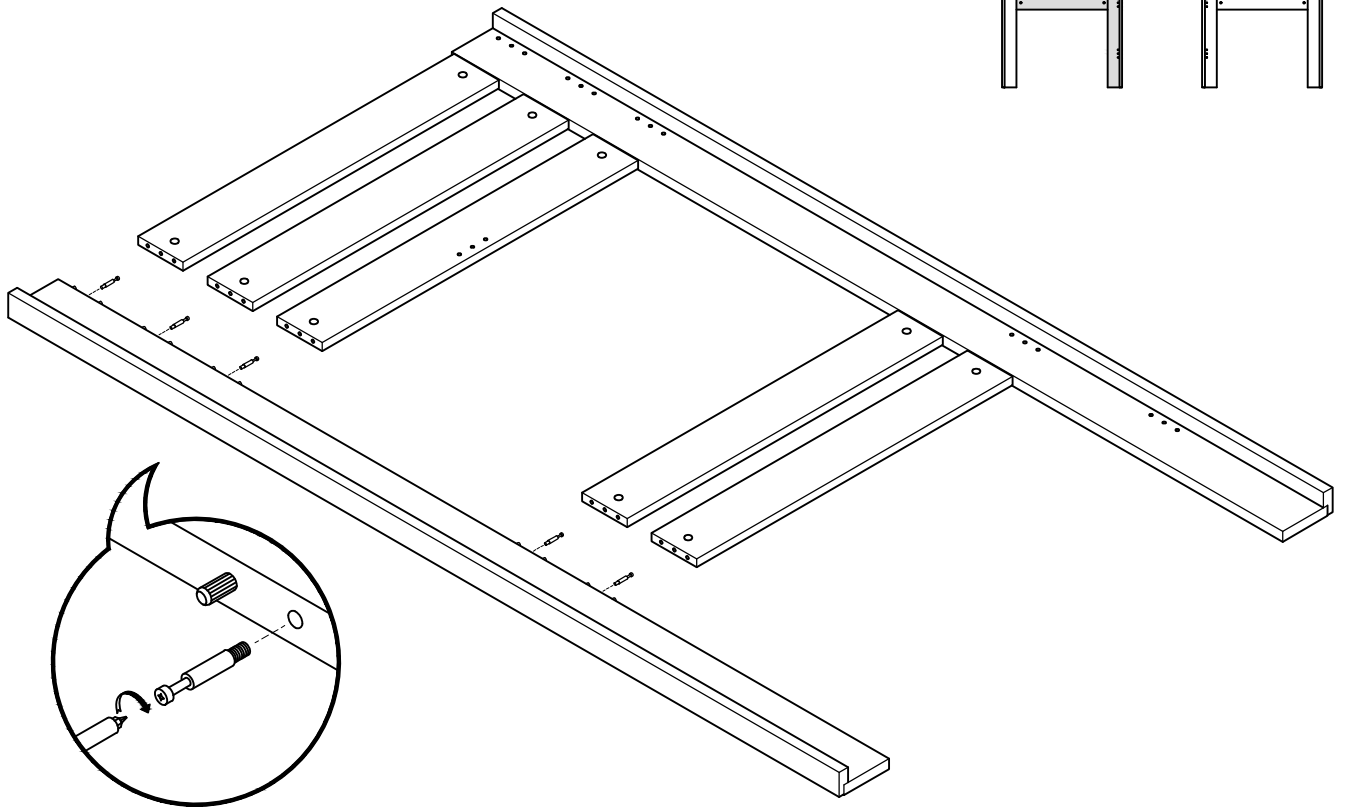
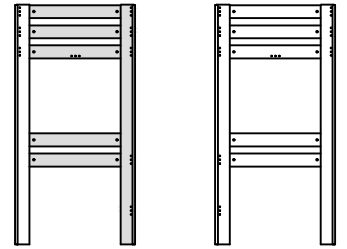

L U F E

5  x 5





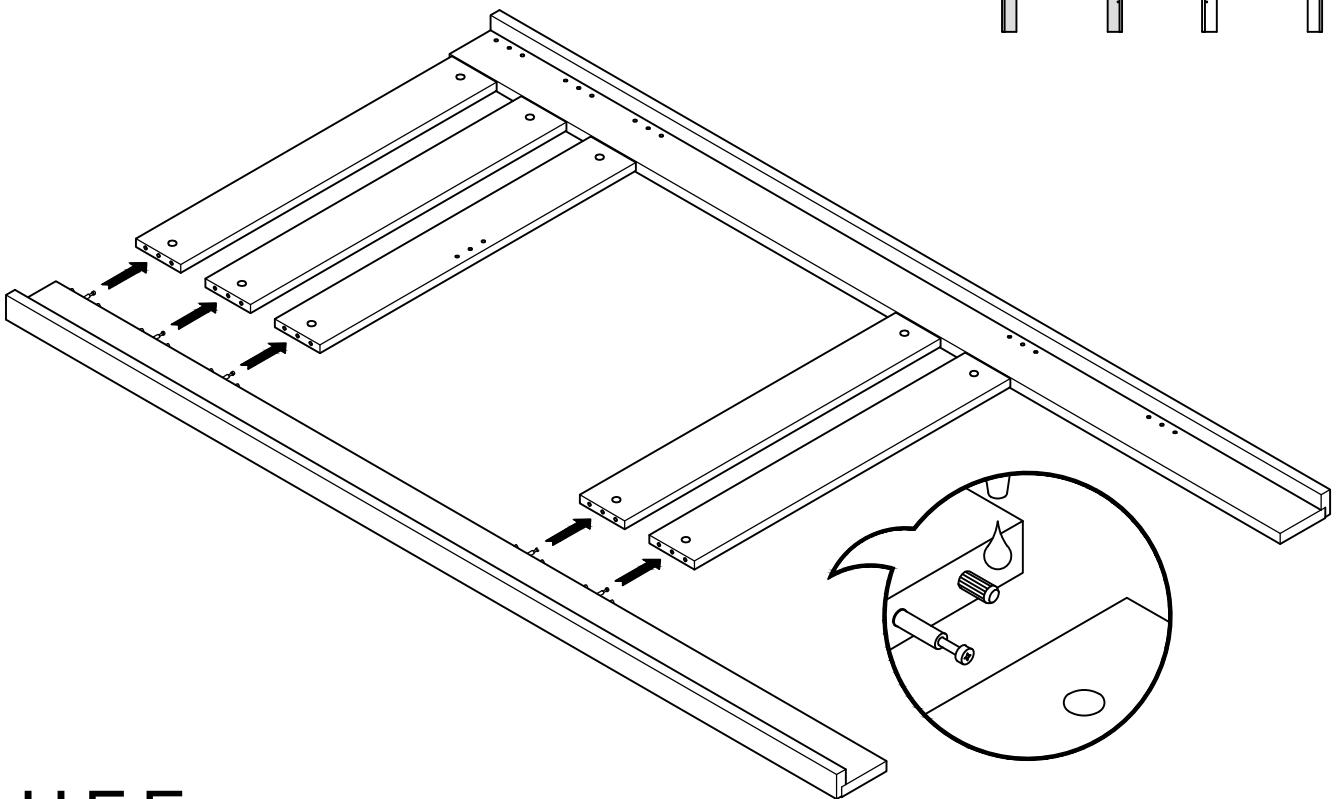
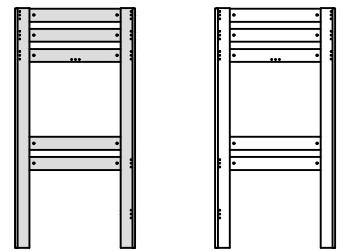

6  x 10

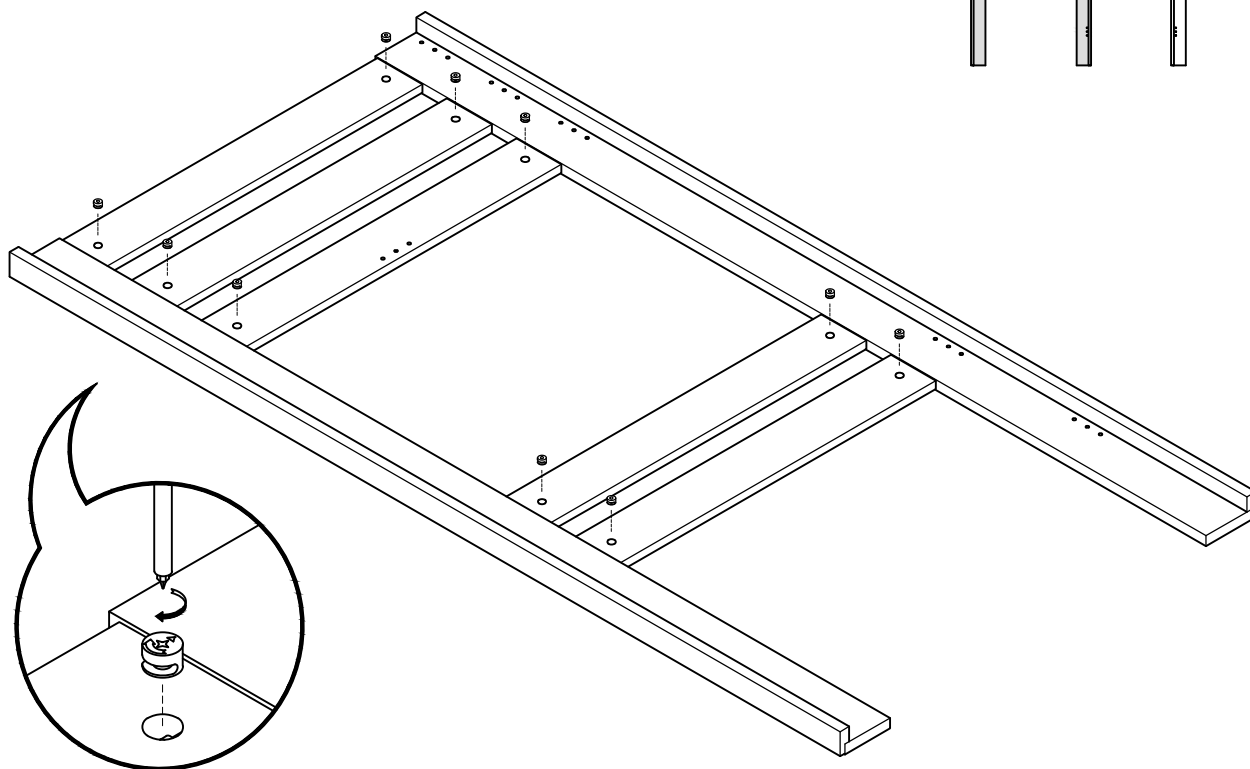
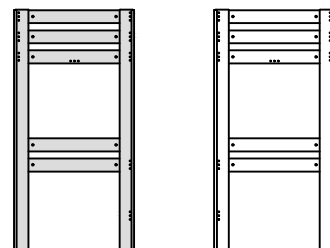

L U F E

7  x 10



8  x 20  x 10  x 10

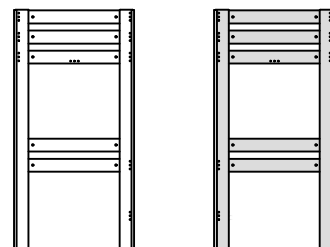

1

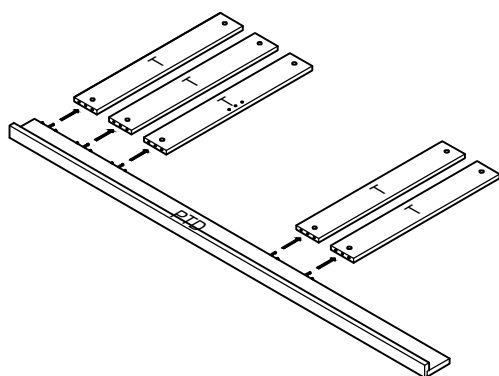

2

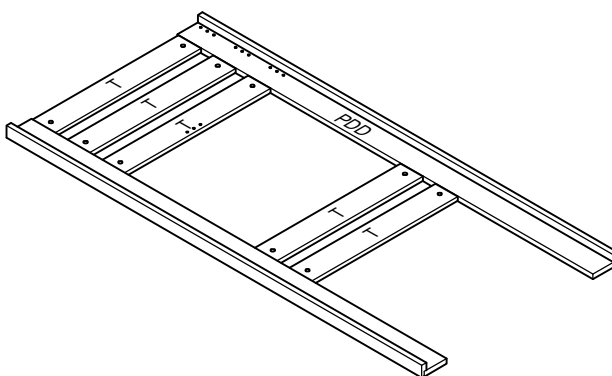

L U F E

9  x 7+7

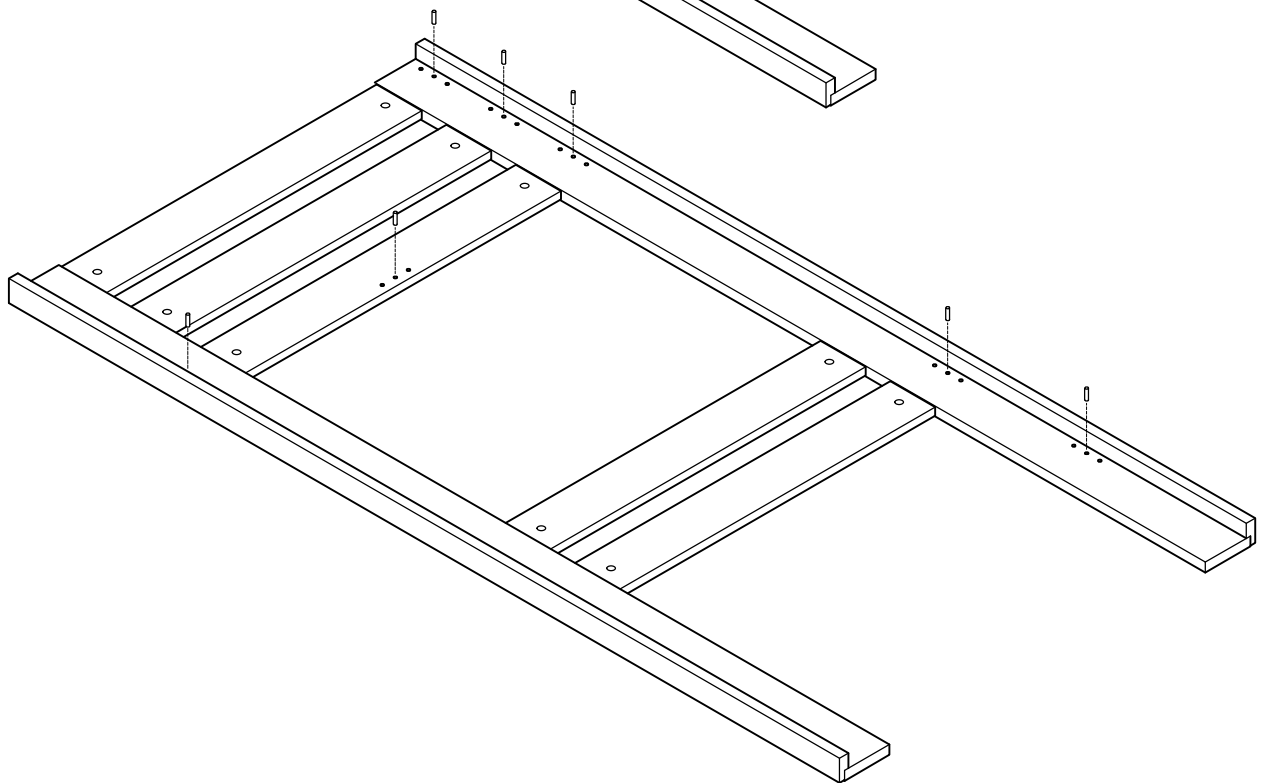
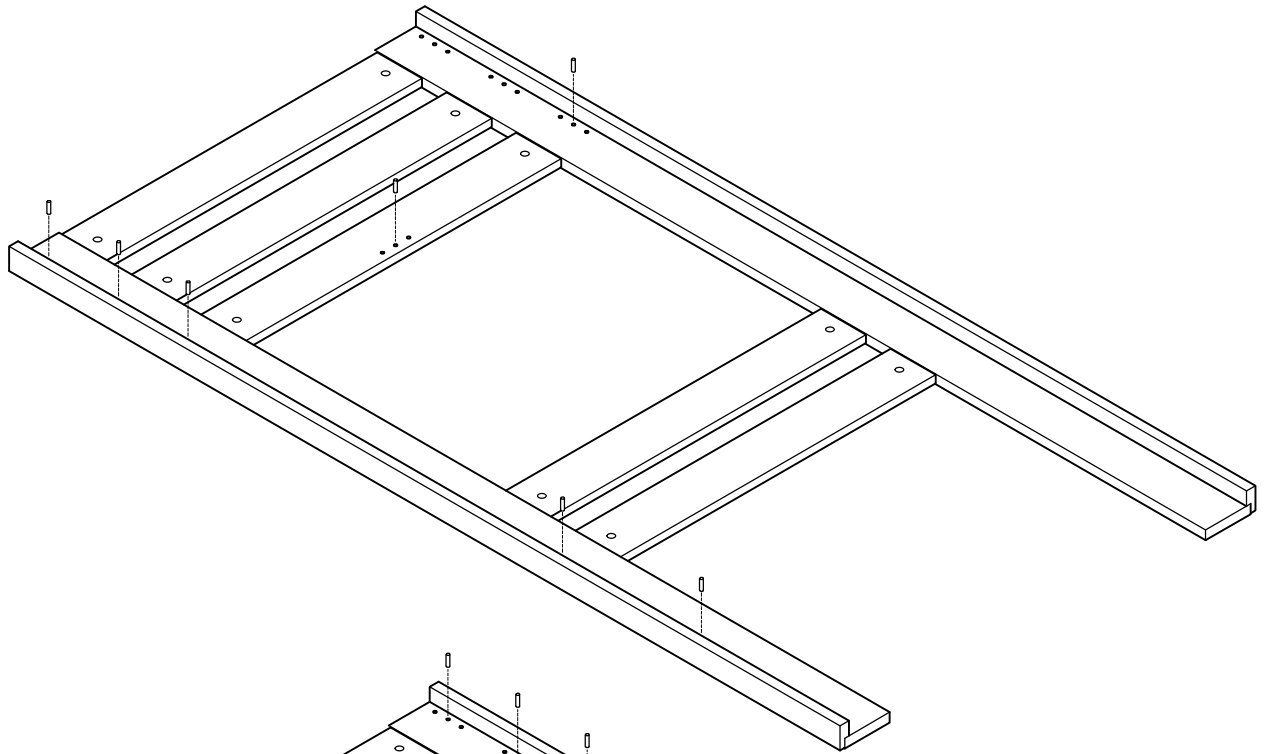
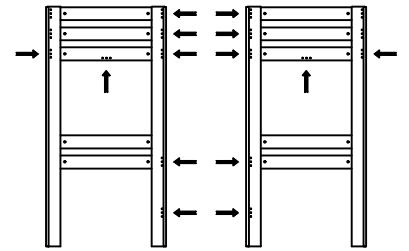

L U F E

10  x 24

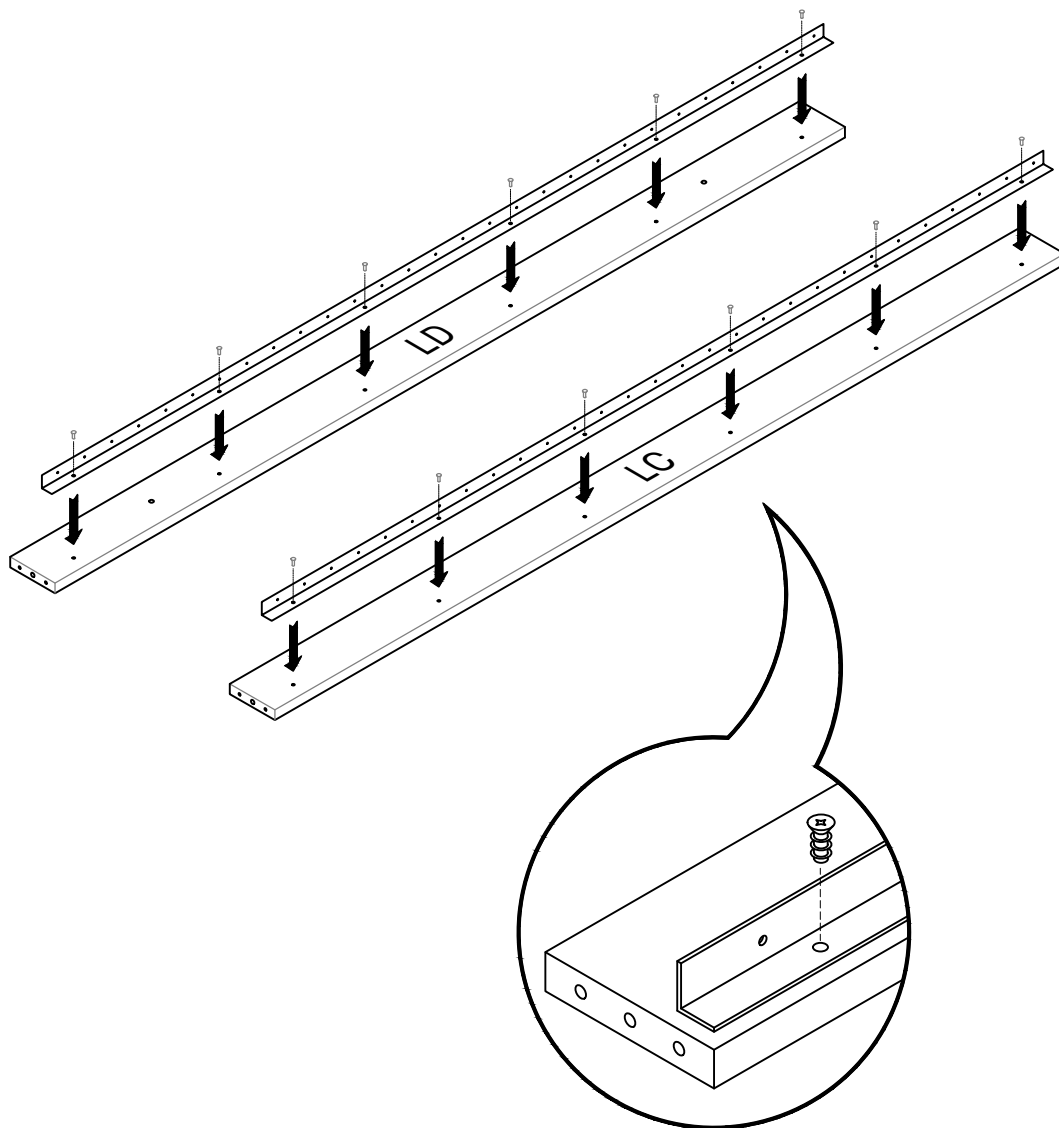

L U F E

11



x 8

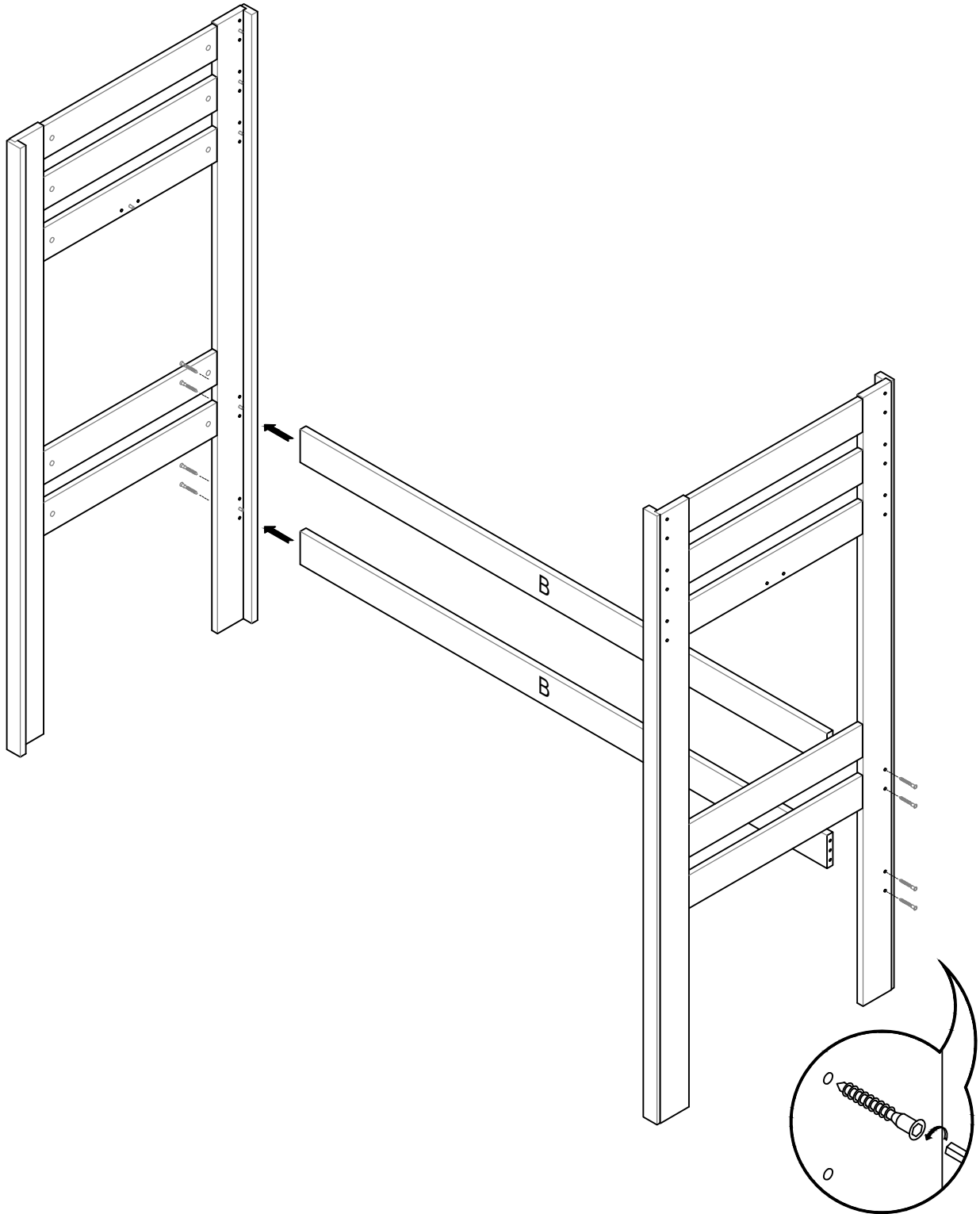
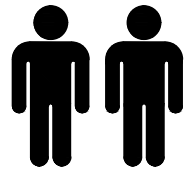

L U F E

12  x 20

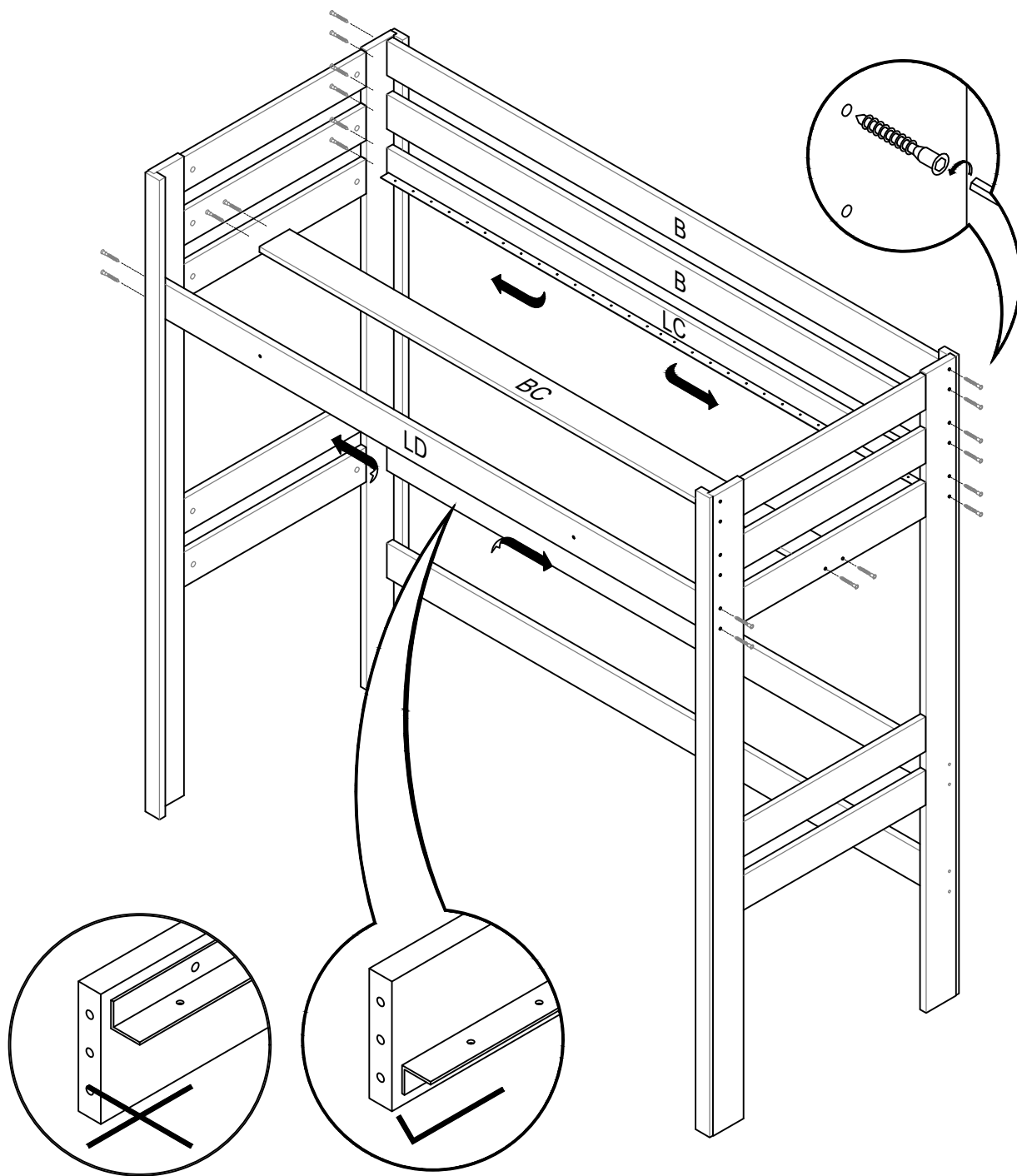
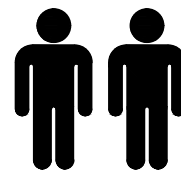

L U F E

13  x 4

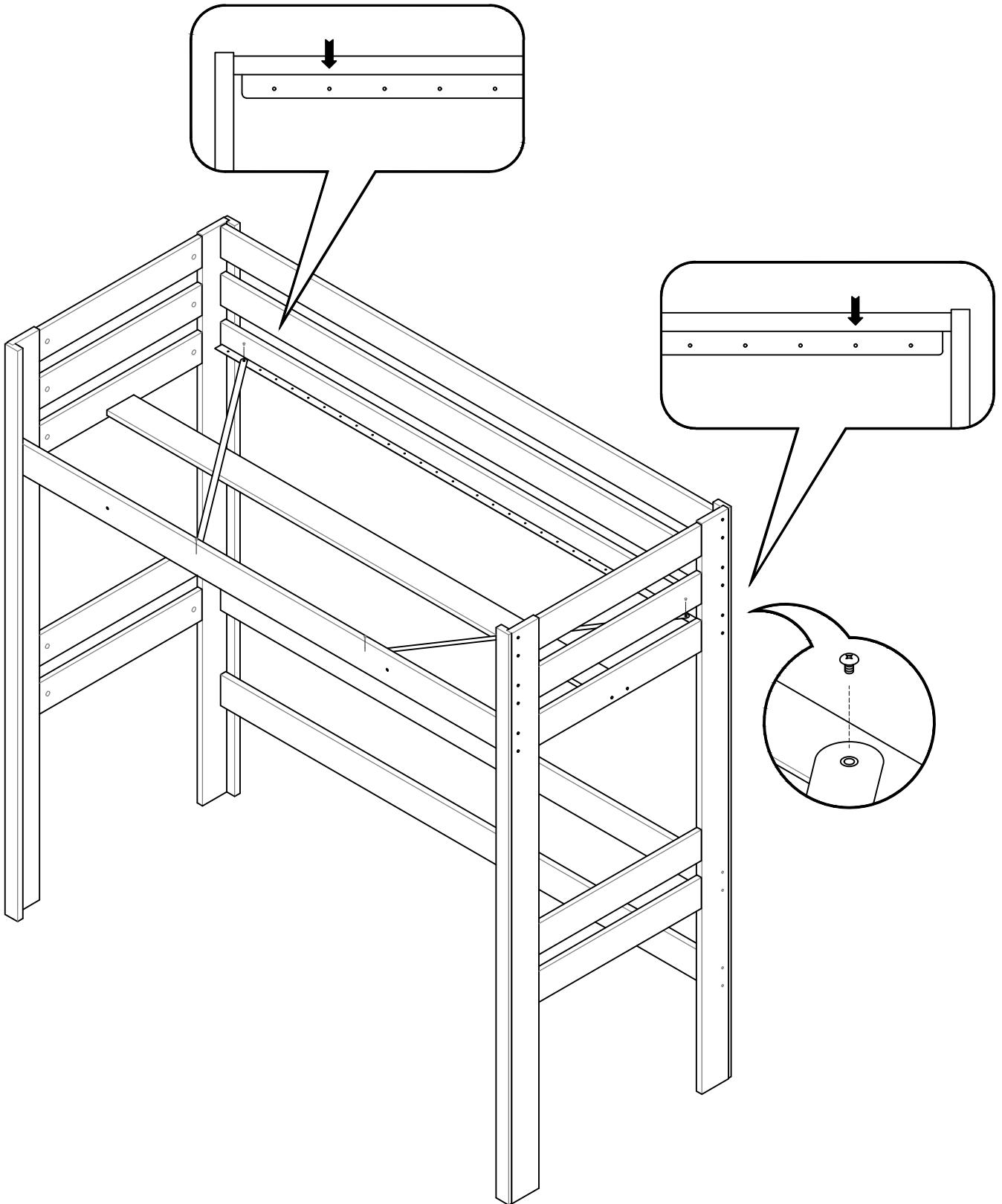
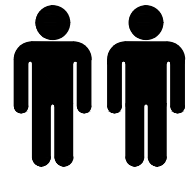

L U F E

14  x 32

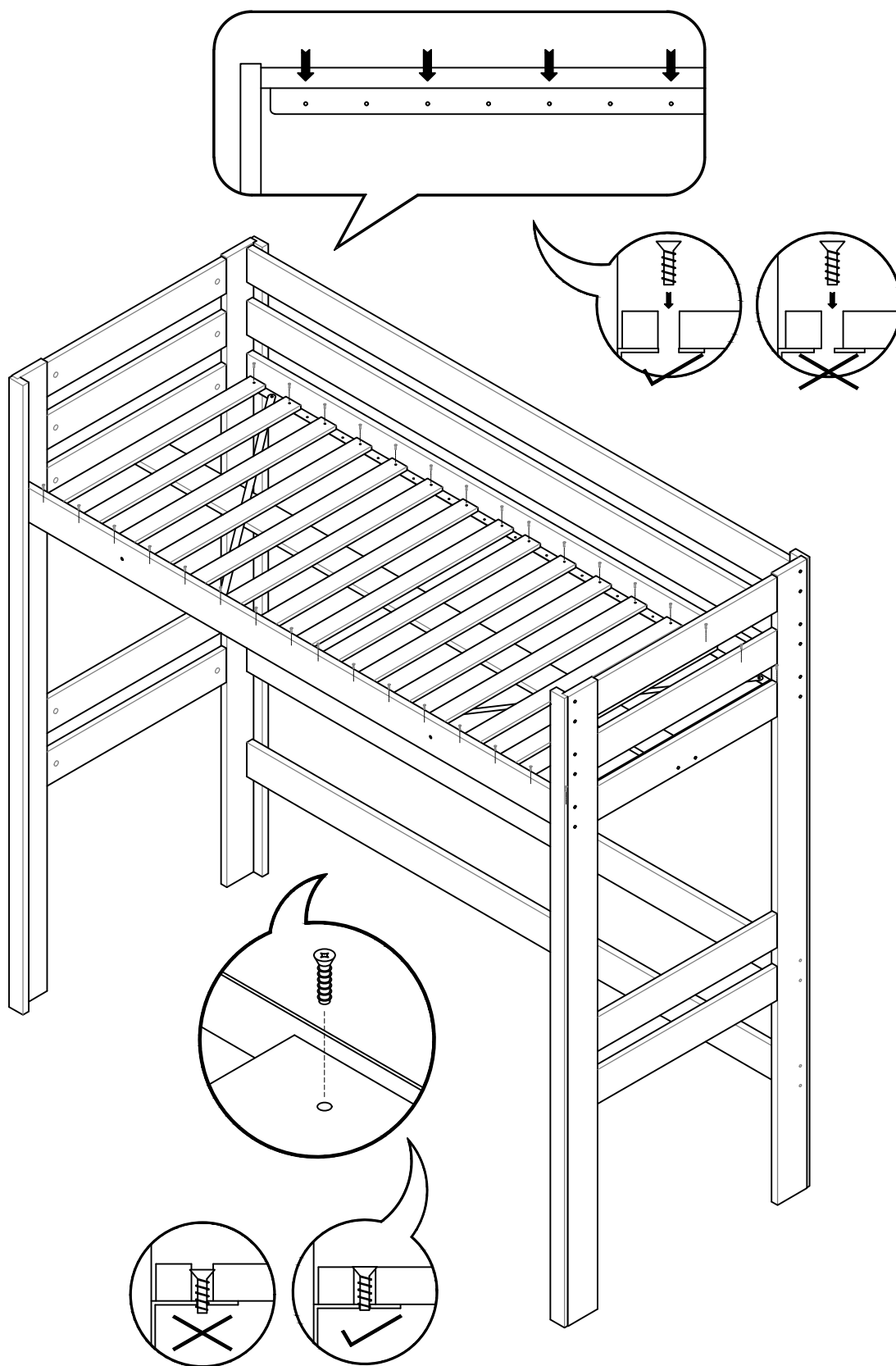
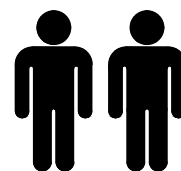

L U F E

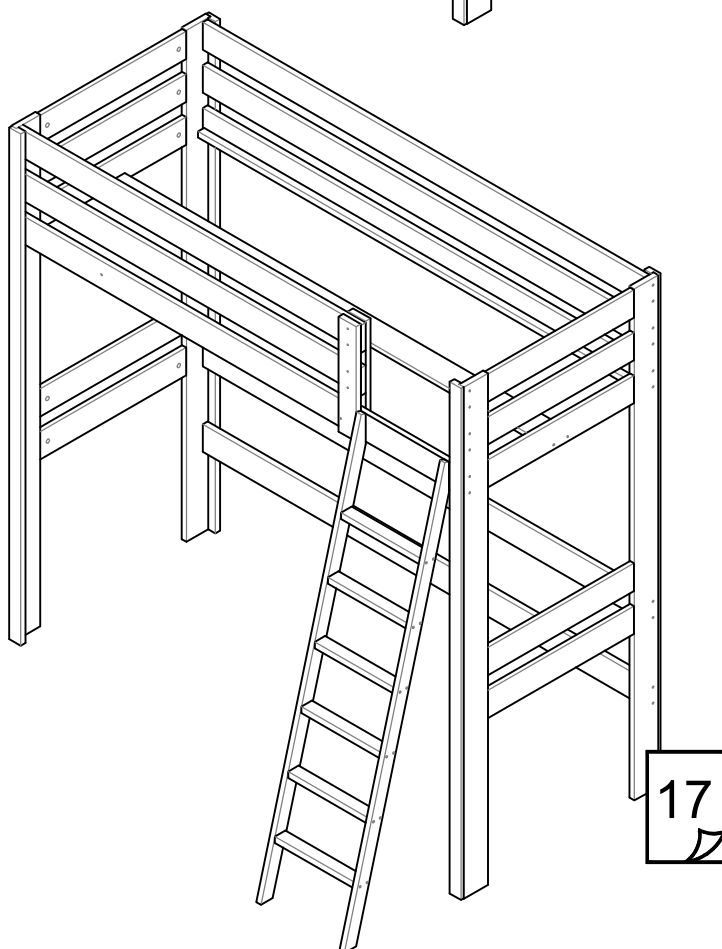
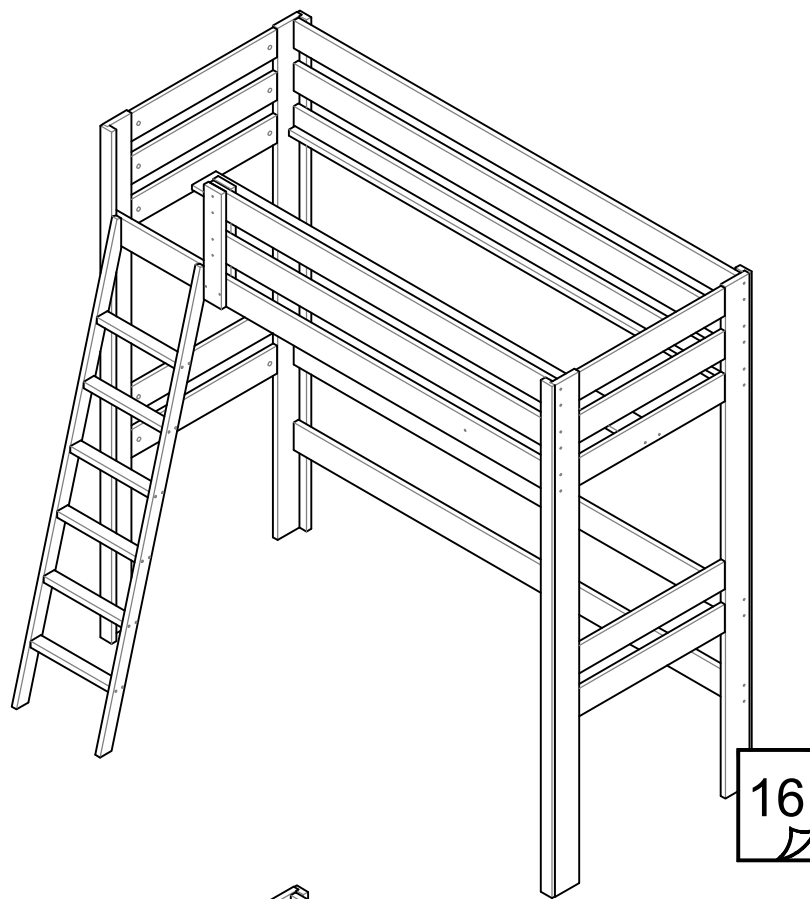

L U F E

15

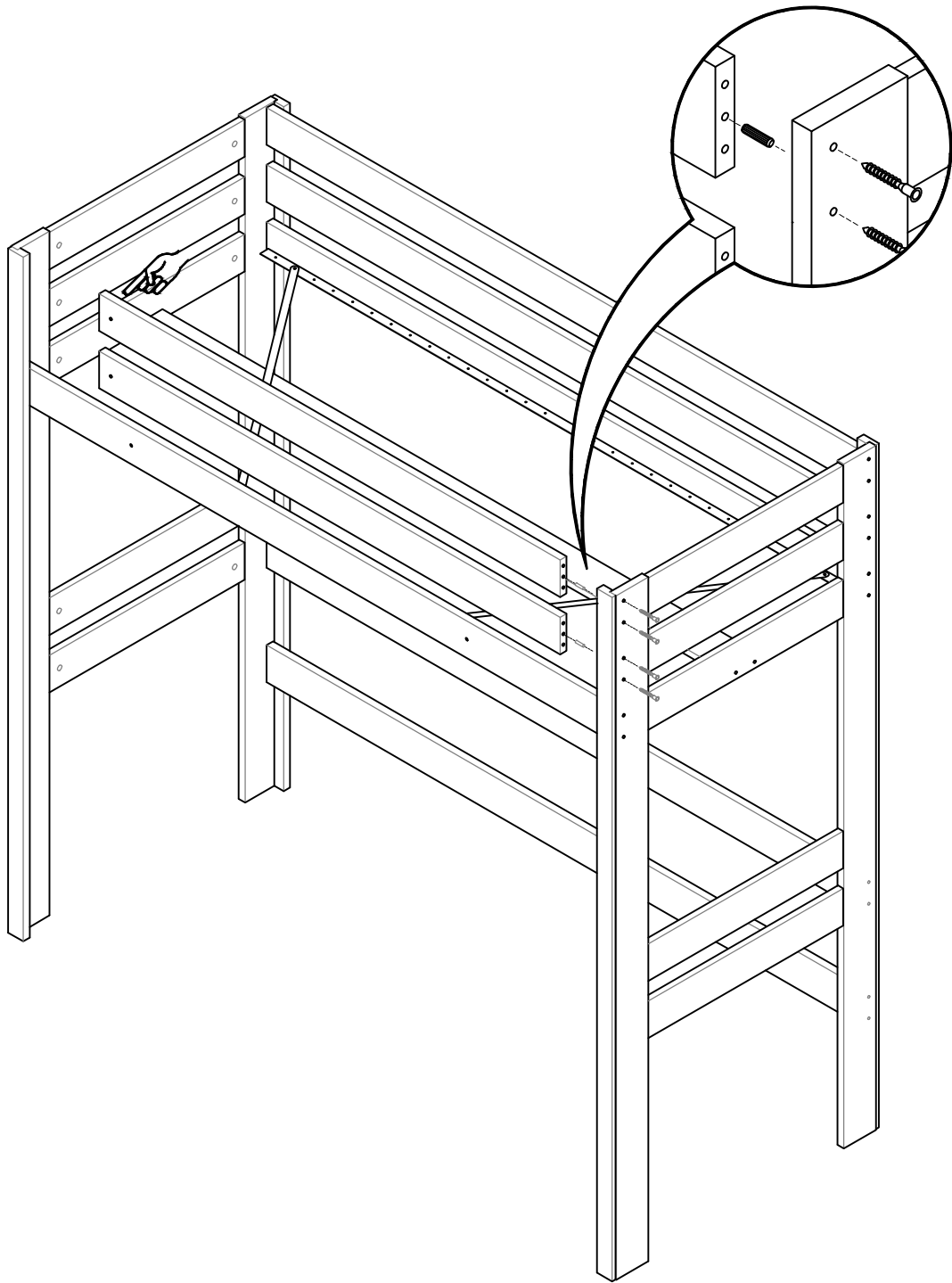
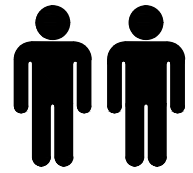
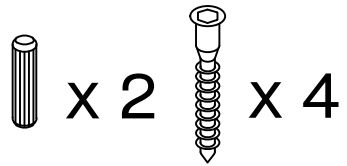

L U F E

16

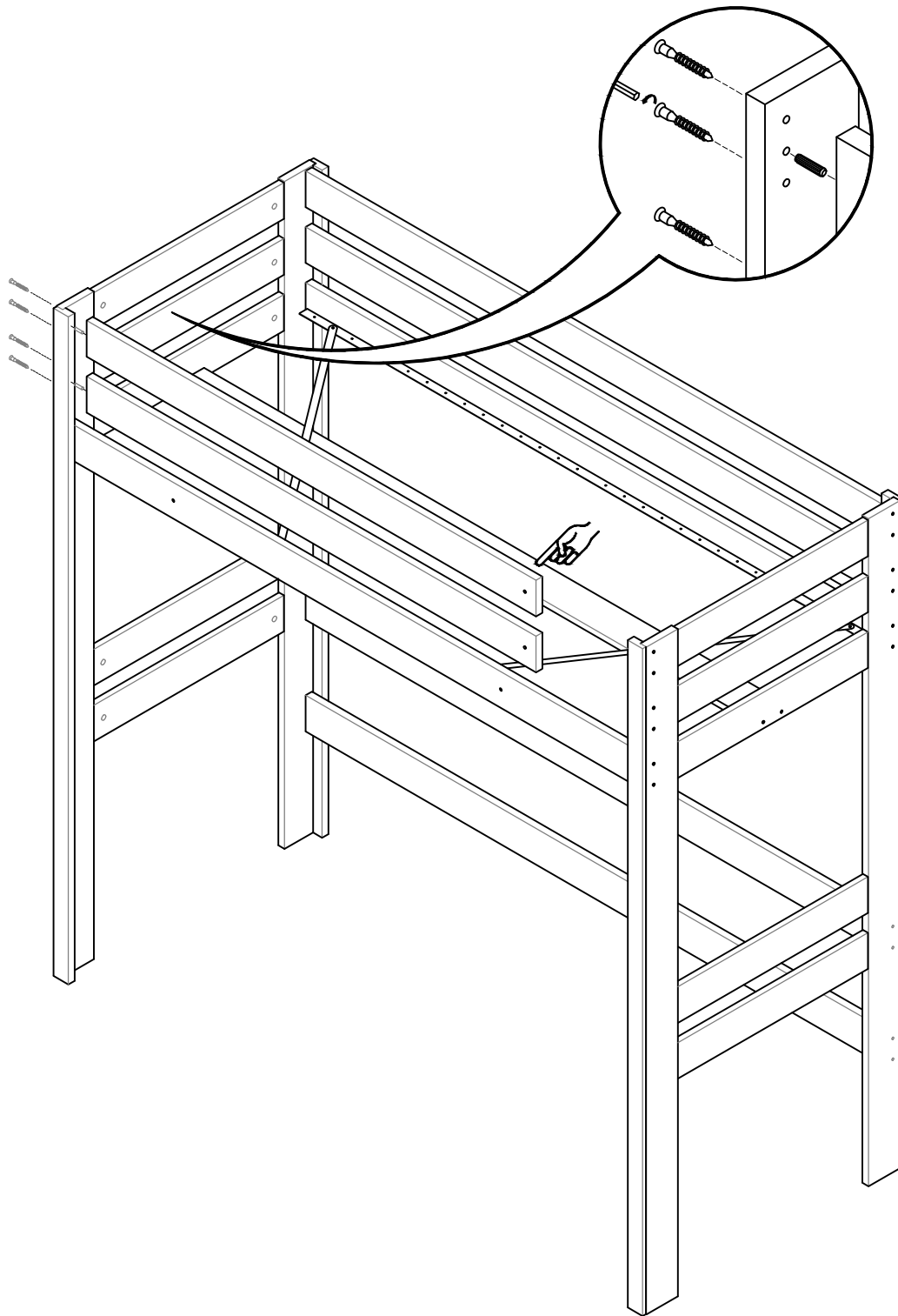
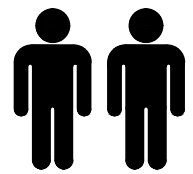
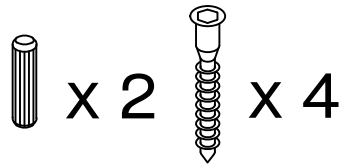

L U F E

17

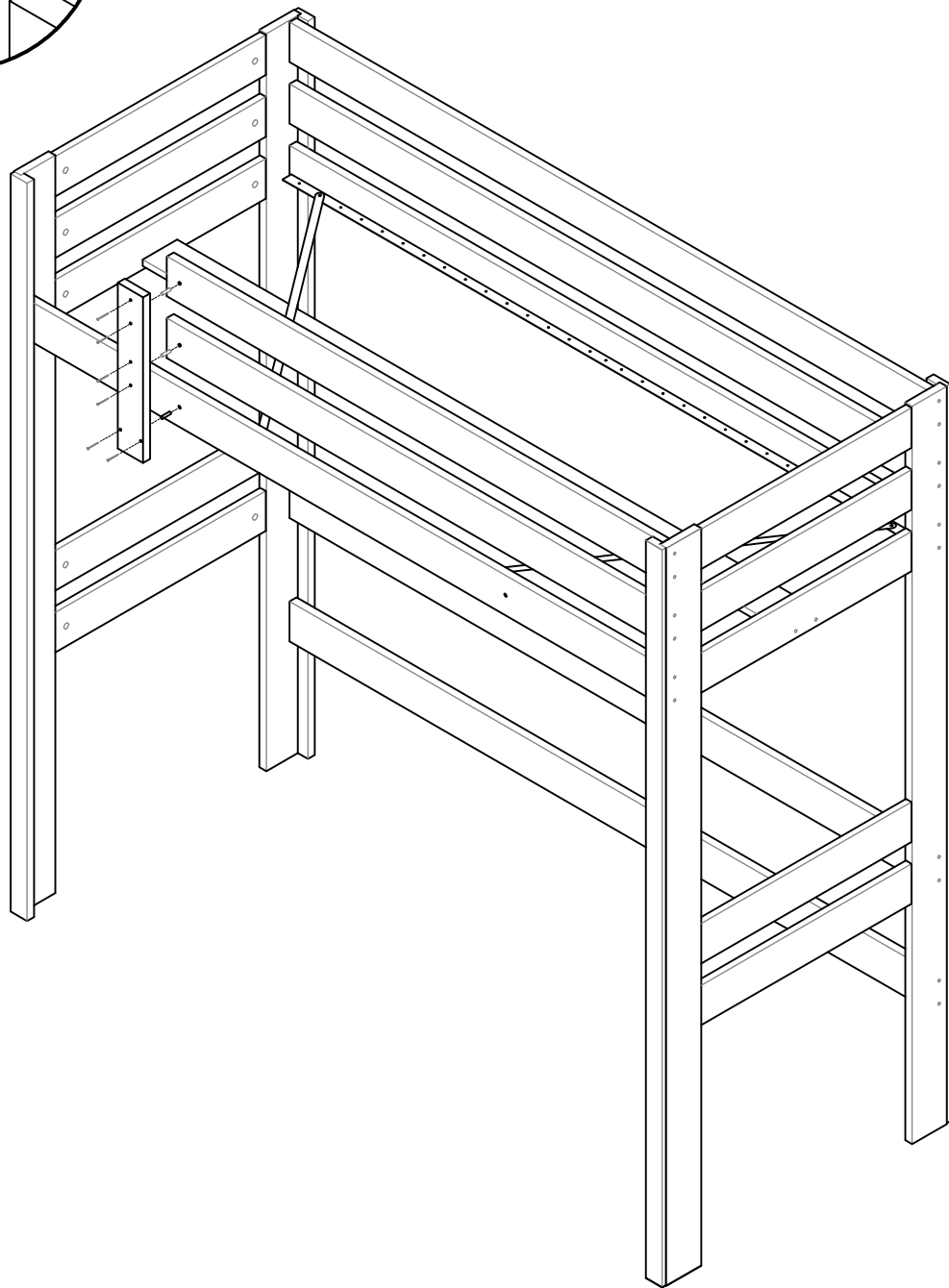
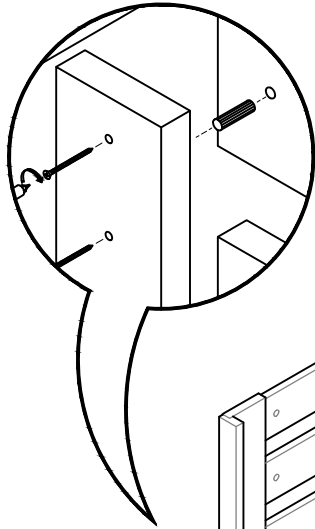
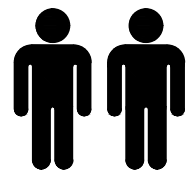
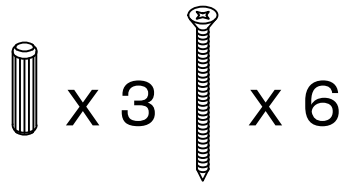

L U F E

18

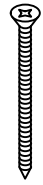

x 4

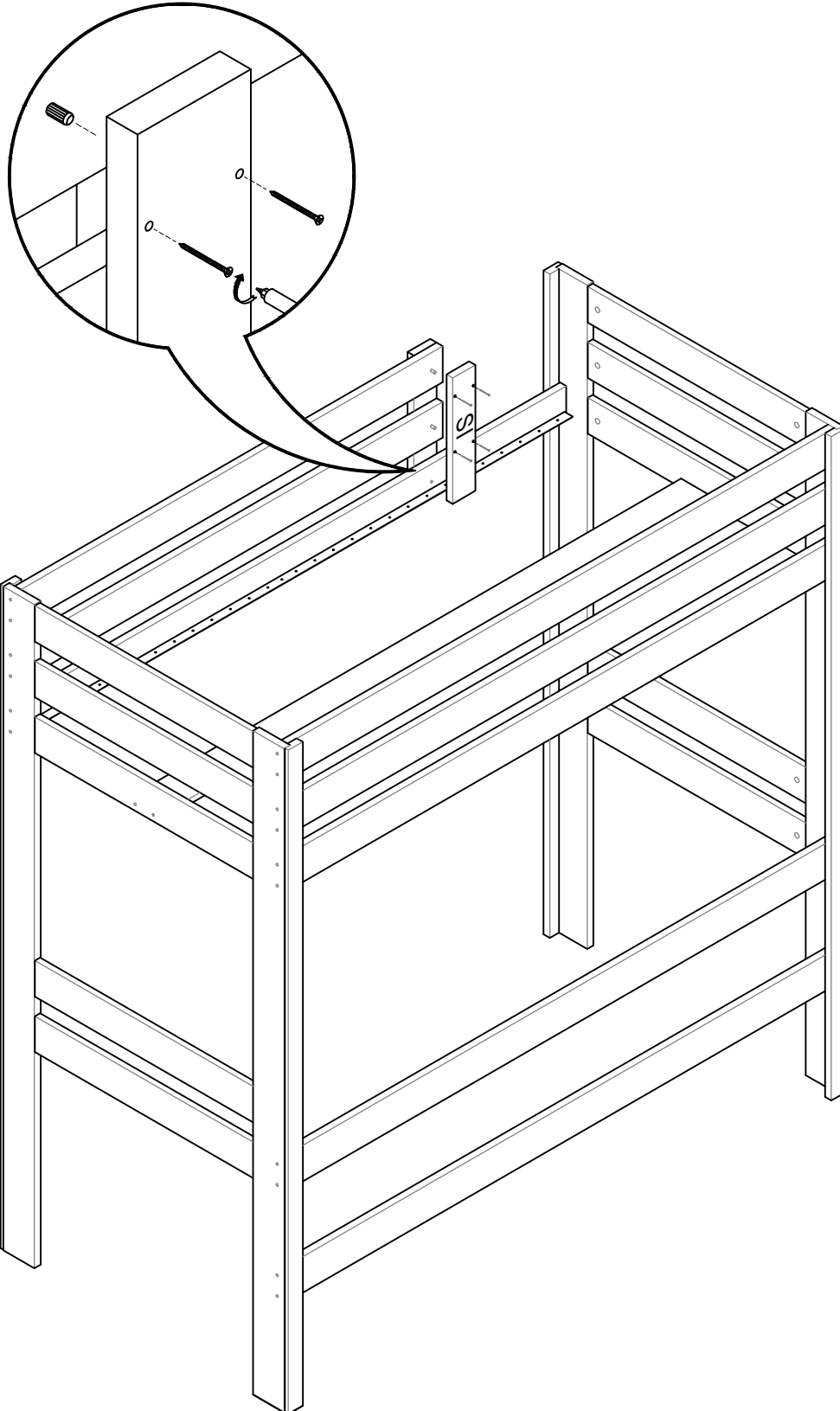
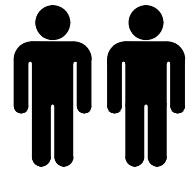

L U F E

19  x 24

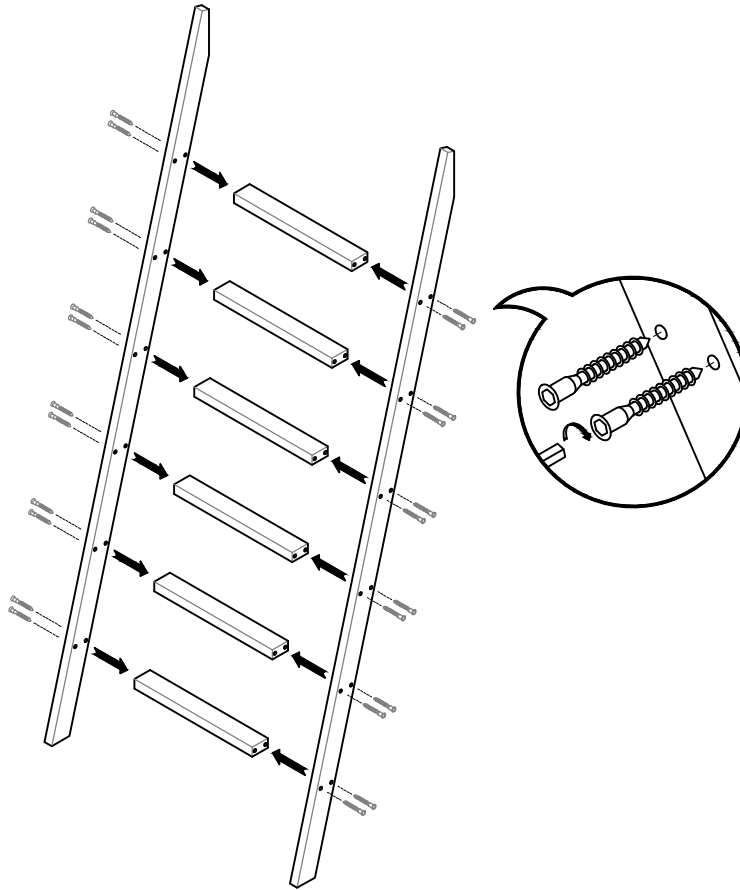

20  x 4

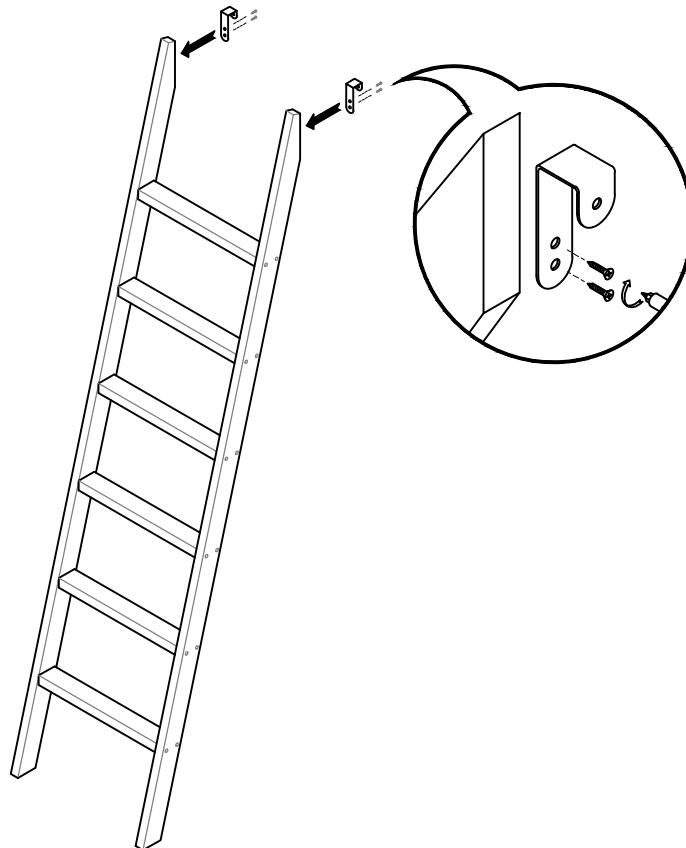

L U F E

21  x 2

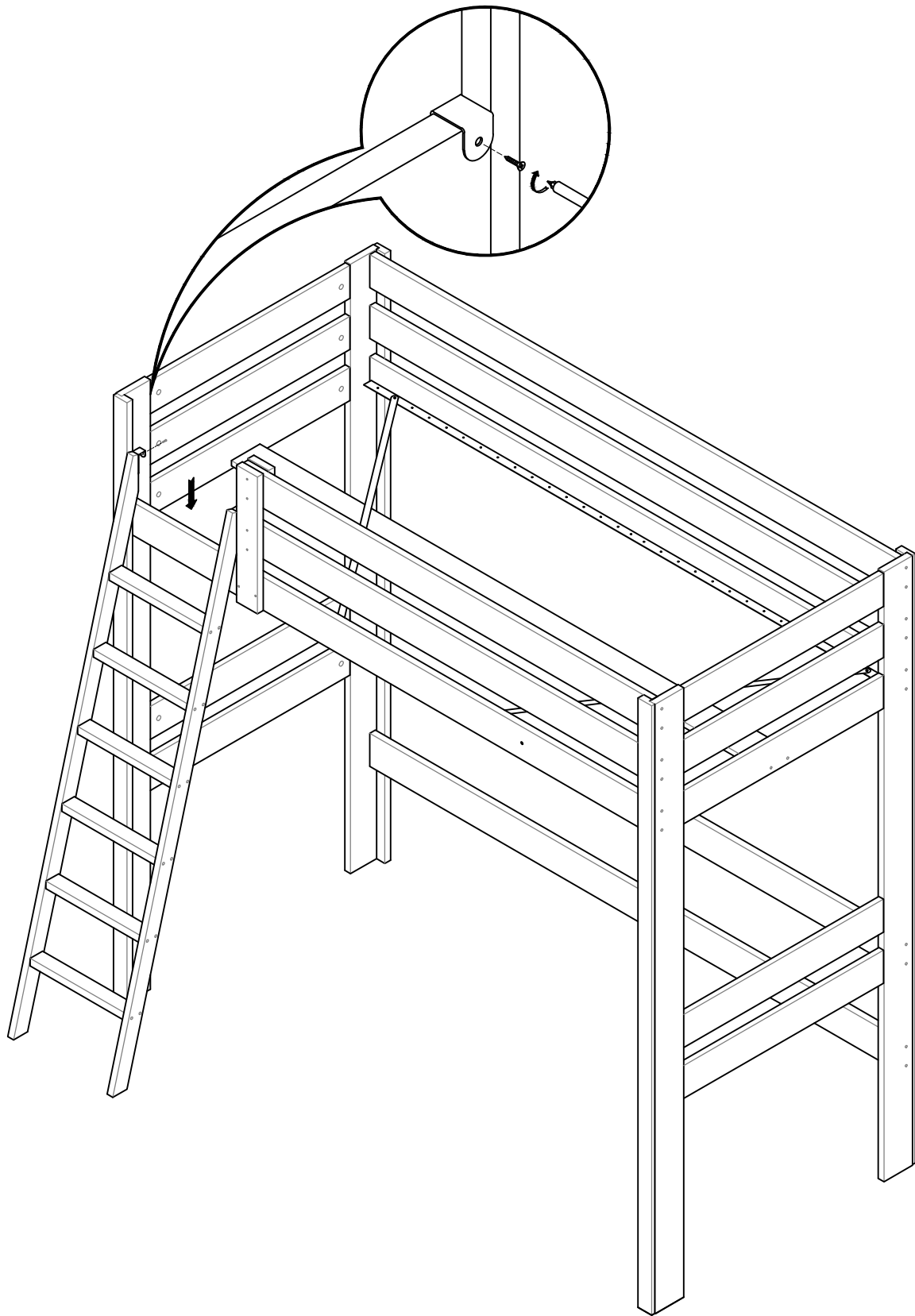

L U F E

20  x 4  x 2

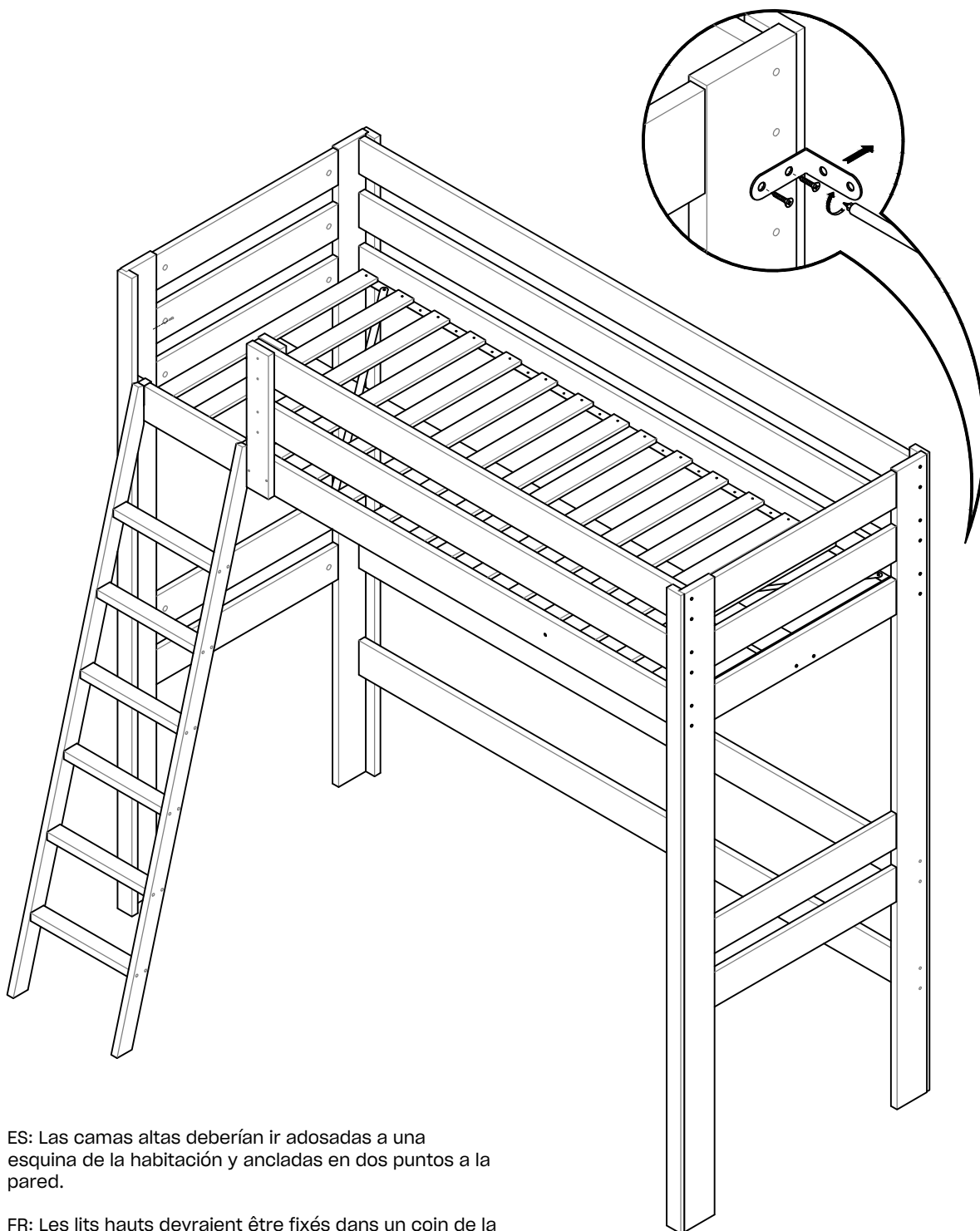

ES: Las camas altas deberían ir adosadas a una esquina de la habitación y ancladas en dos puntos a la pared.

FR: Les lits hauts devraient être fixés dans un coin de la pièce et ancrés au mur en deux points.

PT: As camas altas deveriam ser colocadas num canto do quarto e fixada em dois pontos na parede.

IT: I letti a soppalco dovrebbero essere fissati in un angolo della stanza e ancorati in due punti del muro.

L U F E

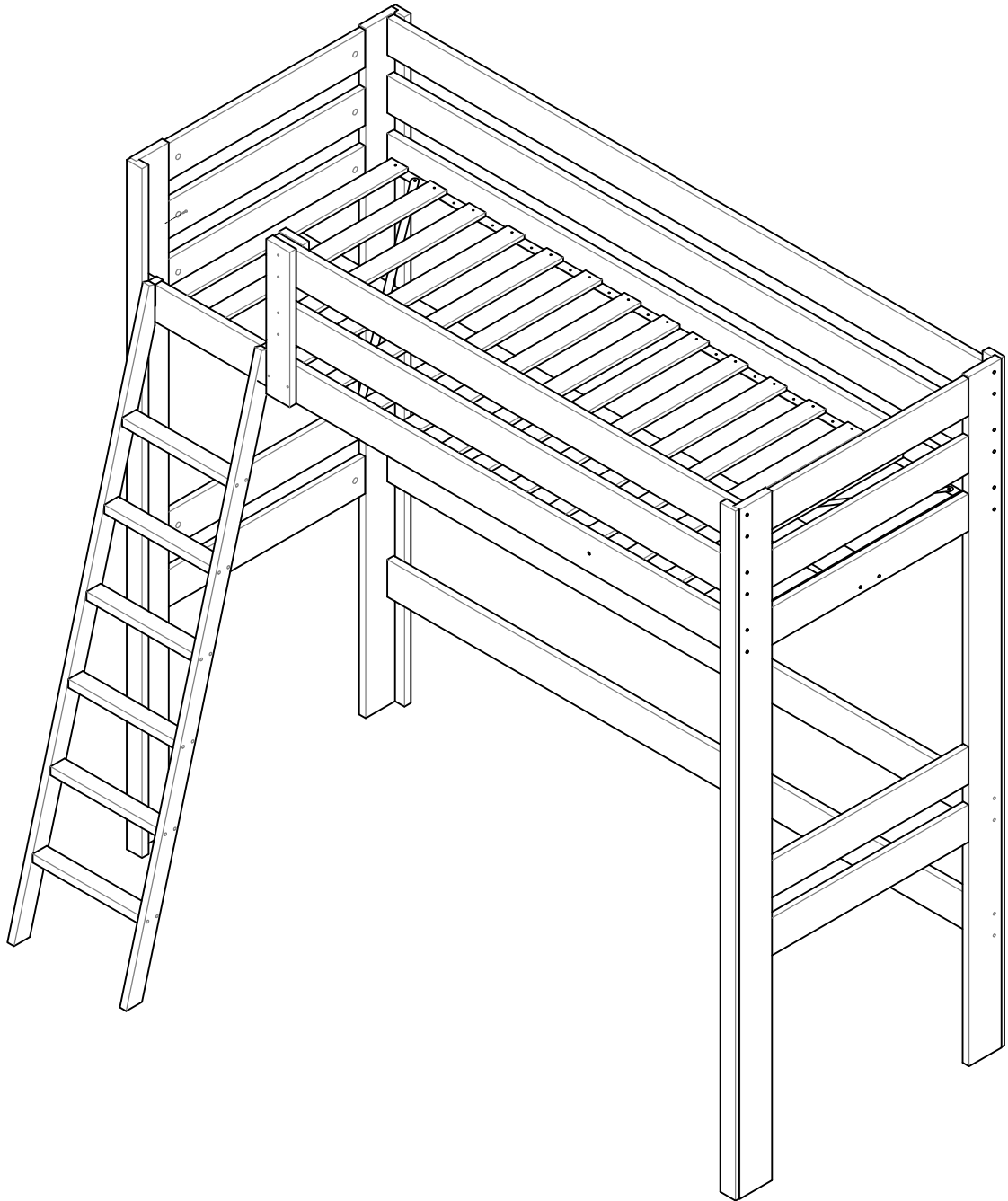

L U F E

ESPAÑA
muebleslufe.com
@muebleslufe

FRANCE
meubleslufe.fr
@lufefrance

PORTUGAL
moveislufe.pt
@lufeportugal

ITALIA
mobililufe.it
@lufemobili

L U F E

TODOLUFE S.L.
Pol. Ind. Etxezarreta 9
20749 Aizarnazabal (Gipuzkoa)

(+34) 943 810 795
info@muebleslufe.com